

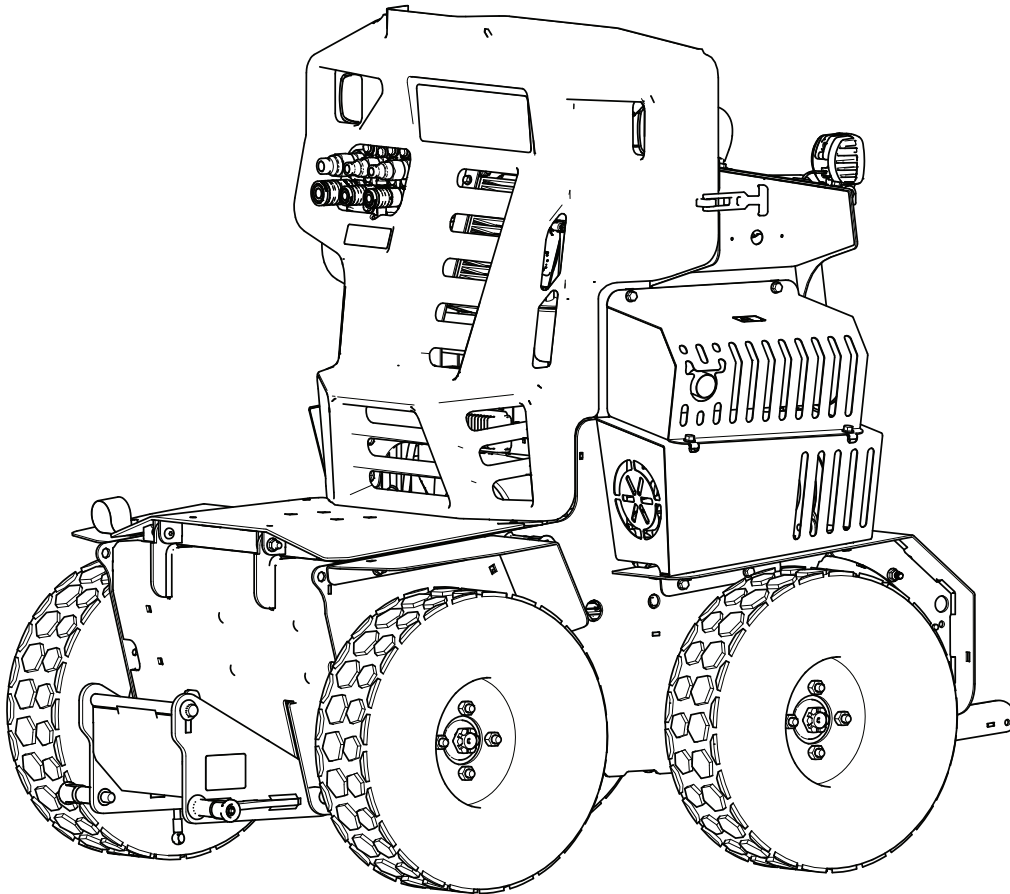


2010 The BOSS Way  
Iron Mountain, MI 49801  
United States

# Owner's Manual

## Snowrator® MAG

Part No. SNR24400—Serial No. 40000000 and Up



This product complies with all relevant European directives; for details, please see the separate product specific Declaration of Conformity (DOC) sheet.

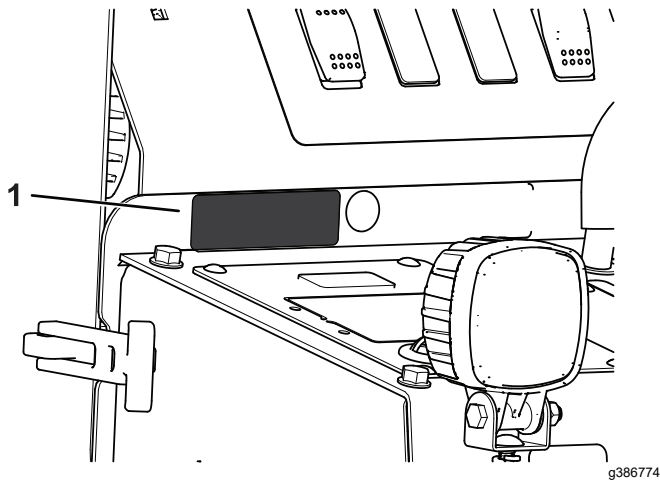
# Introduction

This stand-on vehicle is intended to be used by professional, hired operators. It is designed to operate a variety of attachments, each of which performs a specialized function. Using this product for purposes other than its intended use could prove dangerous to you and bystanders.

Read this information carefully to learn how to operate and maintain your product properly and to avoid injury and product damage. You are responsible for operating the product properly and safely.

Visit [www.bossplov.com](http://www.bossplov.com) for product safety and operation training materials, accessory information, help finding a dealer, or to register your product.

Whenever you need service, genuine BOSS parts, or additional information, contact an Authorized BOSS Dealer or BOSS Technical Service (1-800-286-4155) and have the model and serial numbers of your product ready. **Figure 1** identifies the location of the model and serial numbers on the product. Write the numbers in the space provided.



**Figure 1**

1. Model and serial number location

<b>Date Purchased</b>	_____
<b>Model No.</b>	_____
<b>Serial No.</b>	_____

This manual identifies potential hazards and has safety messages identified by the safety-alert symbol (**Figure 2**), which signals a hazard that may cause serious injury or death if you do not follow the recommended precautions.



**Figure 2**  
Safety-alert symbol

g000502

This manual uses 2 words to highlight information. **Important** calls attention to special mechanical information and **Note** emphasizes general information worthy of special attention.

# Contents

- Safety ..... 3
  - General Safety ..... 3
  - Safety and Instructional Decals ..... 4
- Setup ..... 7
  - Installing the Joysticks ..... 7
  - Connecting the Battery Cables ..... 7
  - Installing the Plastic Cover ..... 8
  - Checking the Tire Pressure ..... 8
- Product Overview ..... 9
  - Controls ..... 9
  - Specifications ..... 9
  - Attachments/Accessories ..... 9
- Before Operation ..... 10
  - Before Operation Safety ..... 10
  - Filling the Fuel Tank ..... 10
  - Performing Daily Maintenance ..... 11
- During Operation ..... 11
  - General Safety ..... 11
  - Slope Safety ..... 12
  - Starting the Engine ..... 12
  - Shutting Off the Engine ..... 12
  - Driving Forward or Backward ..... 12
  - Understanding the Display Screen Information ..... 13
- After Operation ..... 15
  - After Operation Safety ..... 15
  - Transporting the Machine ..... 15
- Maintenance ..... 17
  - Maintenance Safety ..... 17
  - Recommended Maintenance Schedule(s) ..... 17
  - Pre-Maintenance Procedures ..... 18
    - Preparing the Machine for Maintenance ..... 18
    - Opening the Machine Covers for Access ..... 18
  - Lubrication ..... 20
    - Greasing the Quick Pins ..... 20
  - Engine Maintenance ..... 20

# Safety

## General Safety

Always follow all safety instructions to avoid serious personal injury.

- Read the *Owner's Manual* before operating or servicing the machine.
- Keep your hands, feet, and clothing away from moving parts and mounting points.
- Do not operate the machine without all guards and other safety protective devices in place and functioning properly on the machine.
- Keep bystanders and children out of the operating area.
- Do not allow children to operate the machine. Allow only people who are responsible, trained, familiar with the instructions, and physically capable to operate the machine.
- Stop the machine, engage the parking brake, shut off the engine, and remove the key before servicing, fueling, or unclogging the machine.

Improperly using or maintaining this machine can result in injury. To reduce the potential for injury, comply with these safety instructions and always pay attention to the safety-alert symbol ▲, which means Caution, Warning, or Danger—personal safety instruction. Failure to comply with these instructions may result in personal injury or death.

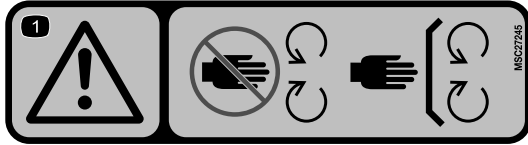
Safety data sheets (SDS) are available at [www.bossplov.com](http://www.bossplov.com) on the Tech Support/Technical Information page.

Engine Safety .....	20
Servicing the Engine .....	20
Servicing the Spark Plug .....	23
Fuel System Maintenance .....	24
Draining the Fuel Tank .....	24
Electrical System Maintenance .....	24
Electrical System Safety .....	24
Servicing the Battery .....	24
Servicing the Fuses .....	26
Drive System Maintenance .....	28
Checking the Tire Pressure .....	28
Checking the Wheel Fasteners .....	28
Belt Maintenance .....	28
Checking the Belts .....	28
Replace the Traction-Drive and Auxiliary-Drive Belt .....	28
Hydraulic System Maintenance .....	30
Hydraulic System Safety .....	30
Hydraulic System Specifications .....	30
Checking the Hydraulic Fluid Level .....	30
Draining the Hydraulic Fluid and Replacing the Filters .....	30
Cleaning .....	32
Cleaning the Machine .....	32
Storage .....	32
Storage Safety .....	32
Storing the Machine .....	32
Removing the Machine from Storage .....	33
Troubleshooting .....	34

# Safety and Instructional Decals



Safety decals and instructions are easily visible and are located near areas of potential danger. Replace every damaged or missing decal.



decalmsc27245

**MSC27245**

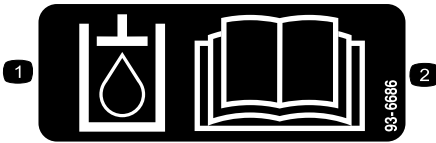
1. Warning—stay away from moving parts; keep all guards and shields in place



decal143-2598

**143-2598**

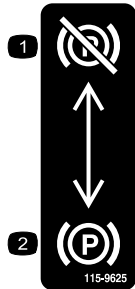
1. Read the *Owner's Manual* for fuel information; do not use fuel containing more than 10% ethanol by volume.



decal93-6686

**93-6686**

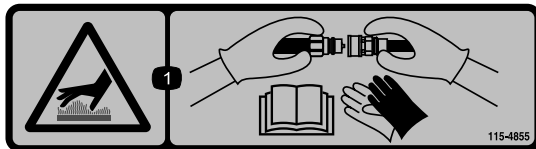
1. Hydraulic fluid
2. Read the *Operator's Manual*.



decal115-9625

**115-9625**

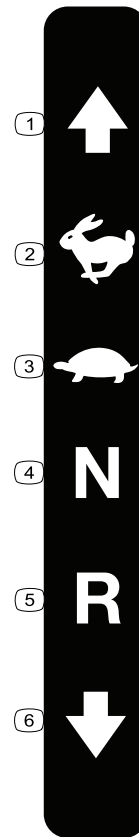
1. Parking brake—disengaged
2. Parking brake—engaged



decal115-4855

**115-4855**

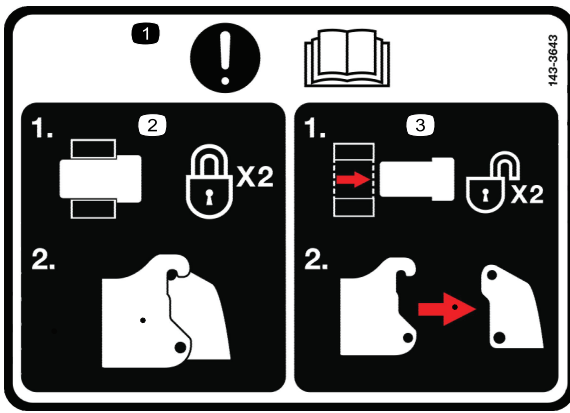
1. Hot surface/burn hazard—wear protective gloves when handling the hydraulic couplers and read the *Operator's Manual* for information on handling hydraulic components.



decal143-2636

**143-2636**

- |            |             |
|------------|-------------|
| 1. Forward | 4. Neutral  |
| 2. Fast    | 5. Reverse  |
| 3. Slow    | 6. Backward |



decal143-3643

**143-3643**

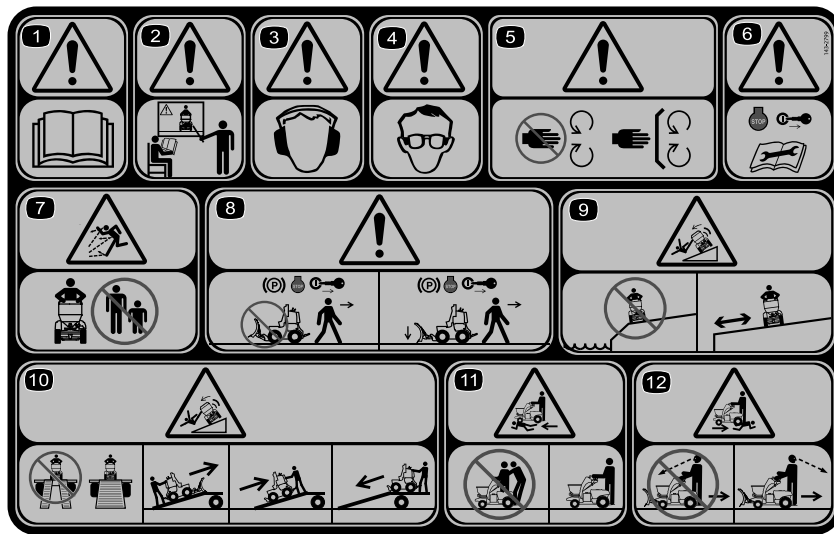
1. Attention—read the *Owner's Manual*.
2. Ensure that the coupler pins are locked in place when using an attachment.
3. Unlock the coupler pins to remove an attachment.



decal143-2649

**143-2649**

1. Forward
2. Neutral
3. Reverse
4. Attachment control
5. Lights
6. On
7. Off
8. InfoCenter
9. Engine—start
10. Engine—run
11. Engine—shut off
12. Engine—run
13. Slow
14. Fast
15. Push up to retract the hydraulic cylinder.
16. Push down to extend the hydraulic cylinder.
17. Push down to raise the attachment
18. Push up to lower the attachment
19. Push all the way up to put the attachment in float position



decal143-2799

**143-2799**

- |   |   |
|---|---|
| <ol style="list-style-type: none"> <li>1. Warning—read the <i>Owner's Manual</i>.</li> <li>2. Warning—all operators should be trained before operating the machine.</li> <li>3. Warning—wear hearing protection</li> <li>4. Warning—wear eye protection</li> <li>5. Warning—keep hands away from moving parts; keep all guards and shields in place.</li> <li>6. Warning—shut off the engine and remove the key before performing maintenance.</li> </ol> | <ol style="list-style-type: none"> <li>7. Thrown object hazard—keep bystanders away</li> <li>8. Warning—engage the parking brake, lower the attachment, shut off the engine, and remove the key before leaving the machine.</li> <li>9. Tipping hazard—do not use the machine near drop-offs; stay at least 2 widths of the machine away from drop-offs.</li> <li>10. Tipping hazard—do not use dual ramps when loading onto a trailer; use 1 ramp wide enough for the machine; walk the machine up the ramp if an attachment is installed, back up the ramp if there is not an attachment installed, walk the machine forward off the ramp when unloading.</li> <li>11. Crushing hazard—do not carry passengers on the machine.</li> <li>12. Crushing hazard—look behind and down when moving in reverse.</li> </ol> |
|---|---|

# Setup

## Installing the Joysticks

Secure the joysticks to the control panel.

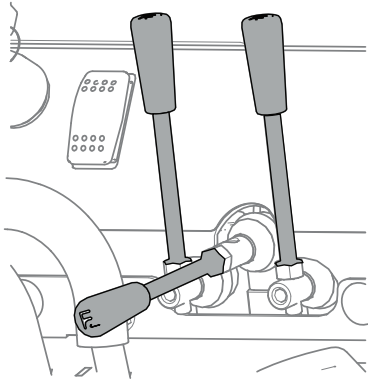


Figure 3

g402621

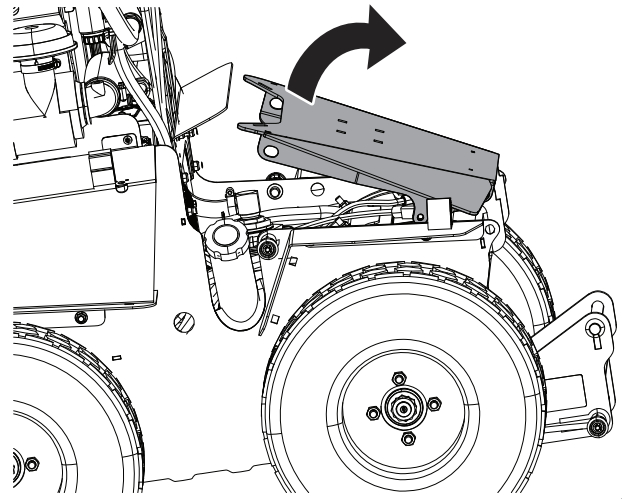


Figure 5

g381901

## Connecting the Battery Cables

Release the quick pins on each side of the machine to release the battery cover (Figure 4 and Figure 5).

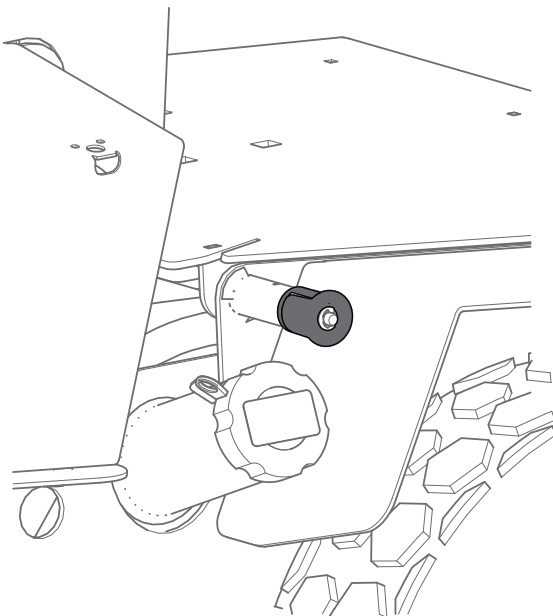


Figure 4

g386773

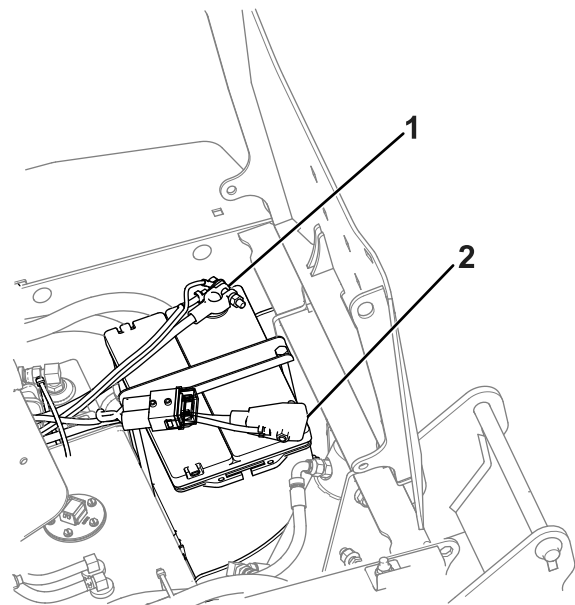


Figure 6

g387508

1. Negative (black)
2. Positive (red)

# Installing the Plastic Cover

Place the tabs into the slots on the frame and secure the cover with the latches (Figure 7 and Figure 8).

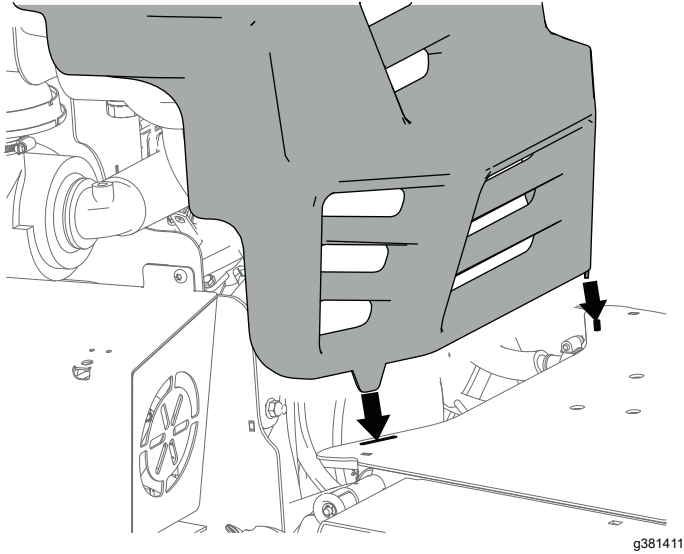


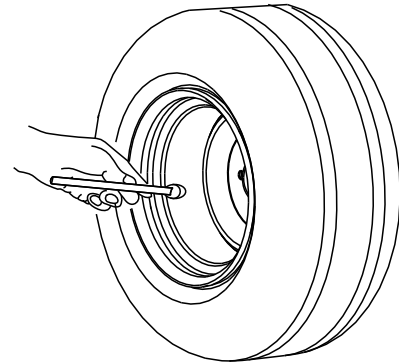
Figure 7

g381411

# Checking the Tire Pressure

Pressure: 124 kPa (18 psi)

Check the air pressure in the tires.



G001055

Figure 9

g001055

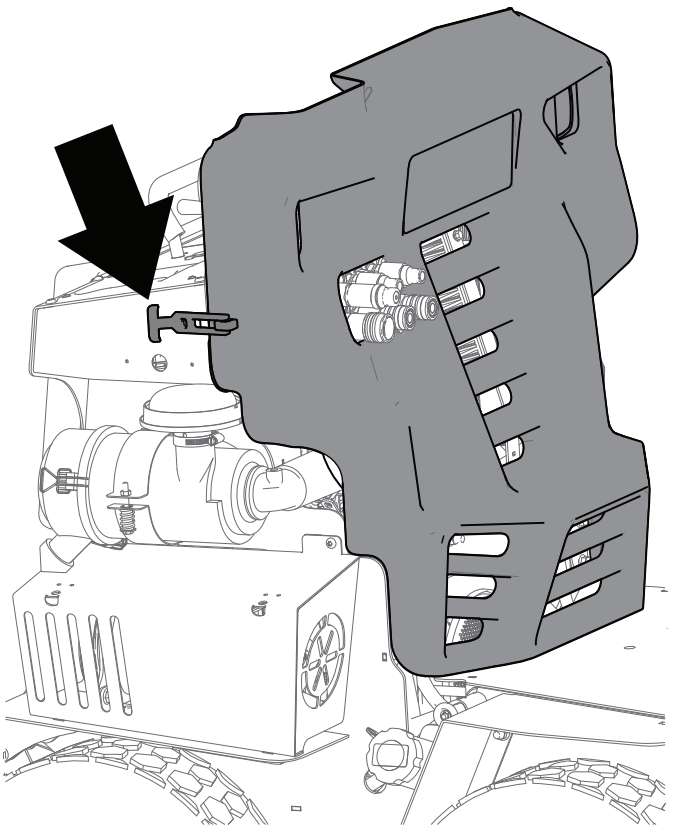


Figure 8

g381410



# Product Overview

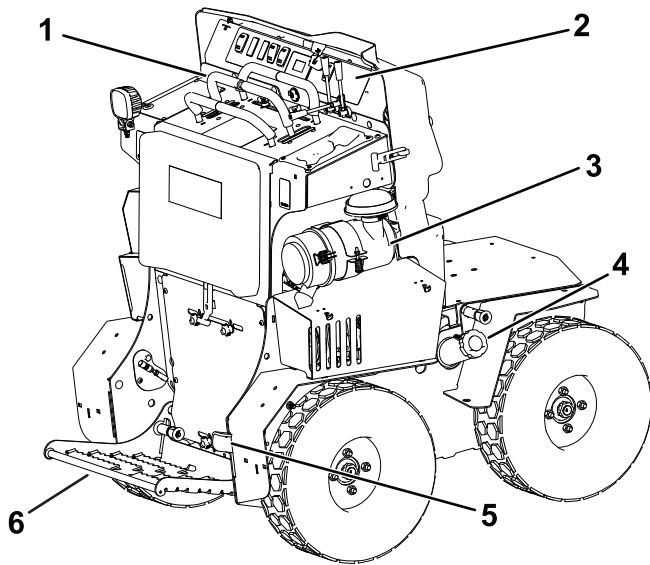


Figure 10

g377860

- |                          |                      |
|--------------------------|----------------------|
| 1. Motion control levers | 4. Fuel cap          |
| 2. Control panel         | 5. Parking brake     |
| 3. Engine air filter     | 6. Operator platform |

## Controls

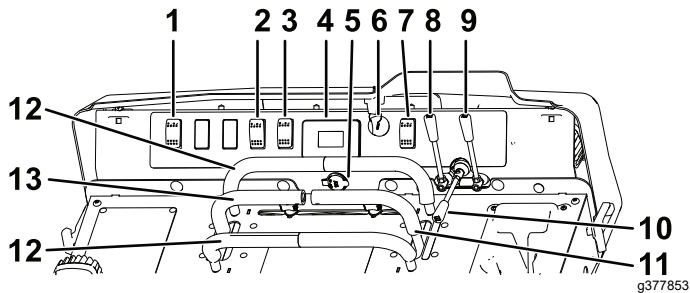


Figure 11

g377853

- |                       |                                |
|-----------------------|--------------------------------|
| 1. Attachment control | 8. Low flow attachment control |
| 2. Light switch       | 9. Low flow attachment control |
| 3. InfoCenter switch  | 10. Raise/lower attachment     |
| 4. InfoCenter         | 11. Right motion-control lever |
| 5. Auxiliary outlet   | 12. Reference bar              |
| 6. Key switch         | 13. Left motion-control lever  |
| 7. Throttle           |                                |

## Attachment Controls

Refer to the *Owner's Manual* or *Installation Instructions* for attachment control information.

## Light Switch

The light switch turns the lights on or off.

## Motion-Control Levers

Use the motion-control levers to drive the machine forward, reverse, and turn either direction.

## Throttle Control

The throttle switch controls the speed (rpm) of the engine. The engine speed will increase by 300 rpm each time the switch is pressed. Hold the switch down for maximum throttle.

## Parking Brake

Press the lever down to engage the parking brake.

Pull the lever up to disengage the parking brake.

## Specifications

**Note:** Specifications and design are subject to change without notice.

Machine Width	100 cm (39-1/2 inches)
Machine Length	1-1/2 m (59 inches)
Machine Height	1 m (50-3/4 inches)
Weight	499 kg (1100 lb)

## Attachments/Accessories

A selection of BOSS approved attachments and accessories is available for use with the machine to enhance and expand its capabilities. Contact your Authorized Service Dealer or authorized BOSS distributor or go to [www.bossplo.com](http://www.bossplo.com) for a list of all approved attachments and accessories.

To ensure optimum performance and continued safety of the machine, use only genuine BOSS replacement parts and accessories. Replacement parts and accessories made by other manufacturers could be dangerous, and such use could void the product warranty.

# Operation

## Before Operation

### Before Operation Safety

#### General Safety

- Never allow children or untrained people to operate the machine. Local regulations may restrict the age of the operator. The owner is responsible for training all operators and mechanics.
- Become familiar with the safe operation of the equipment, operator controls, and safety signs.
- Know how to stop the machine and shut off the engine quickly.
- Check that safety switches and guards are attached and functioning properly. Do not operate the machine unless they are functioning properly.
- Before using the machine, always inspect the machine to ensure that the attachment is in good working condition.
- Ensure that all fluid line connectors are tight and that all hoses are in good condition before applying pressure to the system.
- Ensure that the operator platform is clear of snow and ice.
- Become familiar with the area when you are using the machine; hidden obstructions such as curbs and pipes can damage the attachment or machine.

#### Fuel Safety

- Fuel is extremely flammable and highly explosive. A fire or explosion from fuel can burn you and others and can damage property.
  - To prevent a static charge from igniting the fuel, place the container and/or machine directly on the ground before filling, not in a vehicle or on an object.
  - Fill the fuel tank outdoors, in an open area, when the engine is cold. Wipe up any fuel that spills.
  - Do not handle fuel when smoking or around an open flame or sparks.
  - Do not remove the fuel cap or add fuel to the tank while the engine is running or hot.
  - If you spill fuel, do not attempt to start the engine. Avoid creating a source of ignition until the fuel vapors have dissipated.
  - Store fuel in an approved container and keep it out of the reach of children.

- Fuel is harmful or fatal if swallowed. Long-term exposure to vapors can cause serious injury and illness.
  - Avoid prolonged breathing of vapors.
  - Keep your hands and face away from the nozzle and the fuel-tank opening.
  - Keep fuel away from your eyes and skin.
- Do not store the machine or fuel container where there is an open flame, spark, or pilot light, such as on a water heater or on other appliances.
- Do not fill containers inside a vehicle or on a truck or trailer bed with a plastic liner. Always place containers on the ground, away from your vehicle before filling.
- Remove the equipment from the truck or trailer and refuel it while it is on the ground. If this is not possible, then refuel from a portable container rather than a fuel-dispenser nozzle.
- Do not operate the machine without the entire exhaust system in place and in proper working condition.
- Keep the fuel-dispenser nozzle in contact with the rim of the fuel tank or container opening at all times until fueling is complete. Do not use a nozzle lock-open device.
- If you spill fuel on your clothing, change your clothing immediately. Wipe up any fuel that spills.
- Never overfill the fuel tank. Replace the fuel cap and tighten it securely.

### Filling the Fuel Tank

Capacity	30.3 L (8.0 US gallons)
Type	Unleaded gasoline
Minimum octane rating	87 (US) or 91 (research octane; outside the US)
Ethanol	No more than 10% by volume
Methanol	None
MTBE (methyl tertiary butyl ether)	Less than 15% by volume
Oil	Do not add to the fuel

Use only clean, fresh (no more than 30 days old), fuel from a reputable source.

**Important:** To reduce starting problems, add fuel stabilizer/conditioner to fresh fuel as directed by the fuel-stabilizer/conditioner manufacturer.

1. Park the machine on a level surface, lower the attachment, move the motion-control levers to the NEUTRAL position, engage the parking brake, shut off the engine, wait for all moving parts to stop, and remove the key.

- Clean around the fuel-tank cap and remove it (Figure 12).

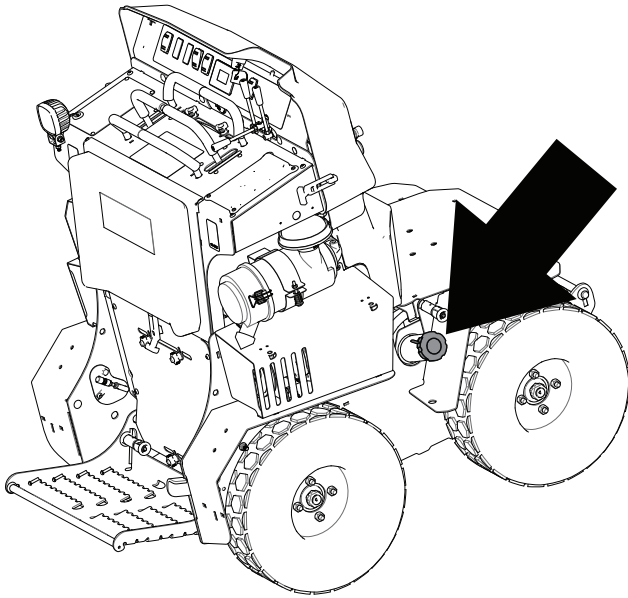


Figure 12

g381935

- Add fuel to the tank until the level is 6 to 13 mm (1/4 to 1/2 inch) below the bottom of the filler neck.

**Important:** This space in the tank allows fuel to expand. Do not fill the fuel tank completely full.

- Install the fuel tank cap securely.
- Wipe up any spilled fuel.

## Performing Daily Maintenance

Before starting the machine each day, perform the Each Use/Daily procedures listed in [Maintenance \(page 17\)](#).

## During Operation

### General Safety

- The owner/operator can prevent and is responsible for accidents that may cause personal injury or property damage.
- Wear appropriate clothing including eye protection, long pants, substantial slip-resistant footwear, and hearing protection. Tie back long hair and do not wear loose clothing or loose jewelry.
- Use your full attention while operating the machine. Do not engage in any activity that causes distractions; otherwise, injury or property damage may occur.
- Do not operate the machine while ill, tired, or under the influence of alcohol or drugs.
- Do not operate the machine when there is the risk of lightning.
- Never carry passengers on the machine and keep bystanders and pets away from the machine during operation.
- Do not climb or ride on the attachment.
- Before you start the engine, ensure that all drives are in neutral and you are in the operating position.
- Never put any part of your body between the attachment and the vehicle.
- Do not operate the machine without good visibility or light.
- Look behind and down before backing up to be sure of a clear path.
- Use extreme care when approaching blind corners, shrubs, trees, or other objects that may block your view.
- Always lower the attachment when the vehicle is not in use.
- Slow down and use caution when making turns and crossing roads and sidewalks with the machine. Always yield the right-of-way.
- Never operate the machine at high transport speeds on slippery surfaces.
- Operate the engine only in well-ventilated areas. Exhaust gases contain carbon monoxide, which is lethal if inhaled.
- Never leave a running machine unattended.
- Before leaving the operating position, do the following:
  - Park the machine on a level surface.
  - Lower the attachment.
  - Move the motion-control levers to the NEUTRAL position.
  - Engage the parking brake.
  - Shut off the engine.
  - Wait for all moving parts to stop.
  - Remove the key.
- Do not use the machine as a towing vehicle.
- Use only accessories and attachments approved by BOSS Products.

## Slope Safety

- Slopes are a major factor related to loss of control and rollover accidents, which can result in severe injury or death. You are responsible for safe slope operation. Operating the machine on any slope requires extra caution. Before using the machine on a slope, do the following:
  - Review and understand the slope instructions in the manual and on the machine.
  - Evaluate the site conditions of the day to determine if the slope is safe for machine operation. Use common sense and good judgment when performing this evaluation. Changes in the terrain, such as moisture, can quickly affect the operation of the machine on a slope.
- Avoid operation on excessively steep slopes.
- Identify hazards at the base of the slope. Do not operate the machine near drop-offs, ditches, embankments, water, or other hazards. The machine could suddenly roll over if a wheel goes over the edge or the edge collapses. Keep a safe distance (twice the width of the machine) between the machine and any hazard. Use a walk-behind machine or a handheld tool to operate in these areas.
- Avoid starting, stopping, or turning the machine on slopes. Avoid making sudden changes in speed or direction; turn slowly and gradually.
- Do not operate a machine under any conditions where traction, steering, or stability is in question. Be aware that operating the machine across slopes or downhill may cause the machine to lose traction. Loss of traction to the drive wheels may result in sliding and a loss of braking and steering. The machine can slide even if the drive wheels are stopped.
- Remove or mark obstacles such as ditches, holes, ruts, bumps, rocks, or other hidden hazards. Deep snow and snowbanks can hide obstacles. Uneven terrain could overturn the machine.
- Use extra care while operating with accessories or attachments. These can change the stability of the machine and cause a loss of control. Follow the directions on [www.bossploow.com](http://www.bossploow.com) for counterweights.
- If you lose control of the machine, step off and away from the direction of travel of the machine.

## Starting the Engine

1. Move the motion-control levers to the NEUTRAL position.
2. Engage the parking brake.
3. Turn the key switch to the ON position.
4. When the machine starts, release the key switch.

## Shutting Off the Engine

1. Park the machine on a level surface.
2. Lower the attachment.
3. Move the motion-control levers to the NEUTRAL position.
4. Engage the parking brake.
5. Turn the key switch to the OFF position and remove the key.

### **⚠ CAUTION**

**Children or bystanders may be injured if they move or attempt to operate the machine while it is unattended.**

**Always remove the key when leaving the machine unattended.**

## Driving Forward or Backward

The throttle control regulates the engine speed as measured in rpm. Place the throttle control in the FAST position for best performance.

### **⚠ CAUTION**

**The machine can spin very rapidly, and you may lose control of the machine, causing personal injury to you and damage to the machine.**

**Slow down the machine before making sharp turns.**

## Driving Forward

Slowly push the motion-control levers forward ([Figure 13](#)).

**Note:** The farther you move the motion-control levers in either direction, the faster the machine moves in that direction.

**Note:** To stop, pull the motion-control levers back to the NEUTRAL position.

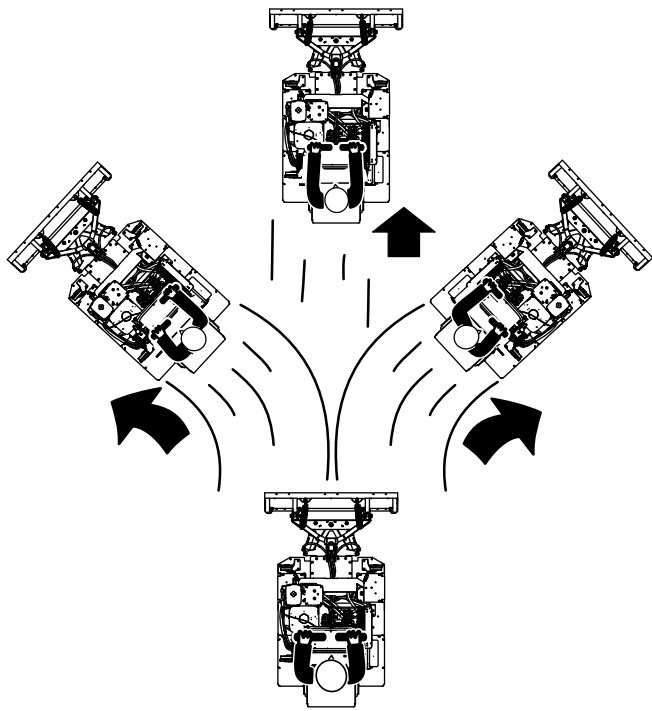


Figure 13

g294499

## Driving Backward

Slowly pull the motion-control levers rearward (Figure 14). Look behind and down while driving backward to ensure you have a clear path.

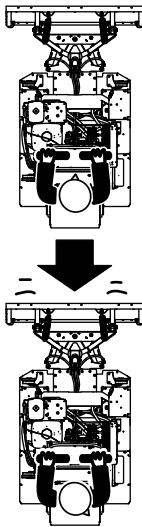


Figure 14

g294500

## Understanding the Display Screen Information

The display screen shows information about your machine, such as the operating status, various diagnostics, and other information about the machine. There are 2 main-information screens (Figure 15) and a main menu screen.



g388641

Figure 15

1. Battery level and hour meter screen
2. Engine temperature screen

## Using the Display-Screen Button

Use the display-screen button (shown in Figure 16) to toggle between the 2 main-information screens and to access the main menu.

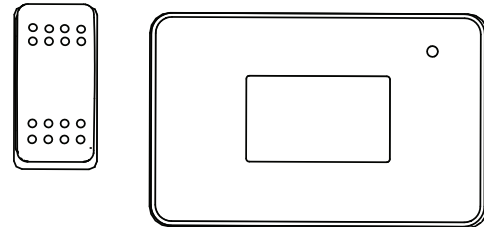


Figure 16

g386776

- **To access the main menu:** Hold down the display-screen button until the menu items appear on the screen.
- **To select a menu item:** Quickly press the display-screen button twice.  
You can also perform this action to toggle an option (e.g., toggling between English or metric units in the SETTINGS screen).
- **To return to the previous screen** (e.g., returning to the MAIN MENU screen from the SETTINGS screen, or returning to the main-information screens from the MAIN MENU screen): Hold down the display-screen button until the previous screen appears.
- **To scroll down to the next menu item:** Press the display-screen button once.

# Understanding the Menu Items

## Main Menu

Menu Item	Description
FAULTS	Contains a list of the recent machine faults. Refer to the Service Manual or your authorized distributor for more information on the FAULTS menu.
SERVICE	Contains information on the machine such as hours of use and counts. Refer to the <a href="#">Service (page 14)</a> table.
DIAGNOSTICS	Lists various states and data that the machine currently has. You can use this information to troubleshoot certain issues, as it quickly tells you which machine controls are on/off and lists control levels (e.g., sensor values).
SETTINGS	Allows you to customize and modify configuration variables on the InfoCenter display. Refer to <a href="#">Settings (page 14)</a> the table.
ABOUT	Lists the model number, serial number, and software version of your machine.

## Service

HOURS	Lists the total number of hours that the auxiliary, key, and engine have been on.
COUNTS	Lists the number of engine and auxiliary starts.


## Diagnostics

AUX	Indicates if the accessory control is active.
ENGINE	Indicates if the engine inputs/outputs are active.





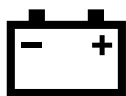






## Settings

CONTRAST	Controls the contrast of the display screen.
UNITS	Controls the units used on the display screen. The menu choices are English or metric.
LANGUAGE	Controls the language used on the display screen.
BACKLIGHT	Controls the brightness of the display screen.
AUX SOFTSTART	When enabled, lowers the engine speed momentarily to reduce hydraulic load when starting an attachment.

## Settings (cont'd.)

AUTOSPEED MODE	When enabled, lowers the engine speed automatically when the machine is in neutral for 4 seconds or immediately as the operator leaves the platform.
OVERRIDE P BRAKE	When enabled, overrides the parking brake interlock in the event of a brake malfunction.
PROTECTED MENUS 	Accessible only by entering PIN
Hydraulic Over Temp Protection	Detects and protects against high hydraulic fluid temperature by reducing the engine speed in steps. This setting is not adjustable.

## Understanding the Display Screen Icons

	Hour meter
	Operator must stand on platform
	Parking Brake Indicator—indicates when the parking brake is on
	Neutral
	Battery voltage
	Engine rpm/status—indicates the engine rpm
	Engine coolant temperature
	Hydraulic fluid temperature
	Fuel level
	AUX highflow
	Hydraulic overtemp protection



## Accessing the Protected Menus

**Note:** The factory default PIN code for your machine is “1234”.

1. Select the SETTINGS option.
2. Select the PROTECTED MENUS option.
3. To enter the Pin code, press the display-screen button until the appropriate digit appears, then quickly press the display-screen button twice to move to the next digit.
4. After all four digits are entered, press the display button once to submit the PIN code.

If the PIN code has been entered correctly, the PIN icon will appear at the top right of all menu screens.

## After Operation

### After Operation Safety

#### General Safety

- Always shut off the machine, engage the parking brake, remove the key, wait for all moving parts to stop, and allow the machine to cool before adjusting, servicing, cleaning, or storing it.
- Clean up oil or fuel spills.
- Never store the machine or fuel container where there is an open flame, spark, or pilot light, such as on a water heater or on other appliances.
- Use full-width ramps for loading the machine into a trailer or truck.
- Tie the machine down securely using straps, chains, cable, or ropes. Both front and rear straps should be directed down and outward from the machine. Refer to [Transporting the Machine \(page 15\)](#).
- When storing the machine for more than 30 days, refer to [Storage \(page 32\)](#) for important information.

## Transporting the Machine

Use a heavy-duty trailer or truck to transport the machine. Use a full-width ramp. Ensure that the trailer or truck has all the necessary brakes, lighting, and marking as required by law. Please carefully read all the safety instructions. Knowing this information could help you or bystanders avoid injury. Refer to your local ordinances for trailer and tie-down requirements.

### ⚠ WARNING

**Driving on the street or roadway without turn signals, lights, reflective markings, or a slow-moving-vehicle emblem is dangerous and can lead to accidents, causing personal injury.**

**Do not drive the machine on a public street or roadway.**

## Selecting a Trailer

### ⚠ WARNING

**Loading a machine onto a trailer or truck increases the possibility of tip-over and could cause serious injury or death (Figure 17).**

- Use only a full-width ramp; do not use individual ramps for each side of the machine.
- Ensure that the length of ramp is at least 4 times as long as the height of the trailer or truck bed to the ground.

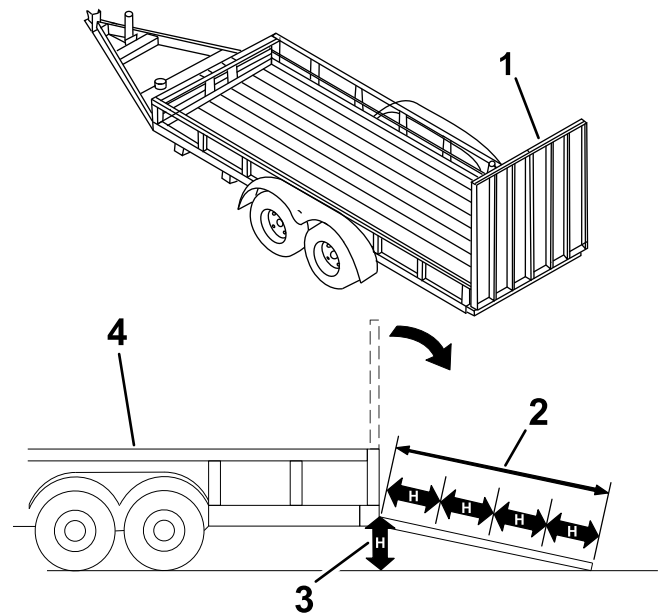


Figure 17

1. Full-width ramp in stowed position
2. Ramp is at least 4 times as long as the height of the trailer or truck bed to the ground
3. H=height of the trailer or truck bed to the ground
4. Trailer

g229507

# Loading the Machine

## ⚠ WARNING

Loading a machine onto a trailer or truck increases the possibility of tip-over and could cause serious injury or death.

- Use extreme caution when operating a machine on a ramp.
  - Walk the machine up the ramp if an attachment is installed; back the machine up the ramp if there is not an attachment installed.
  - Avoid sudden acceleration or deceleration while driving the machine on a ramp as this could cause a loss of control or a tip-over situation.
1. If using a trailer, connect it to the towing vehicle and connect the safety chains.
  2. If applicable, connect the trailer brakes and lights.
  3. Lower the ramp.
  4. Walk the machine up the ramp if an attachment is installed; back the machine up the ramp if there is not an attachment installed (Figure 18).

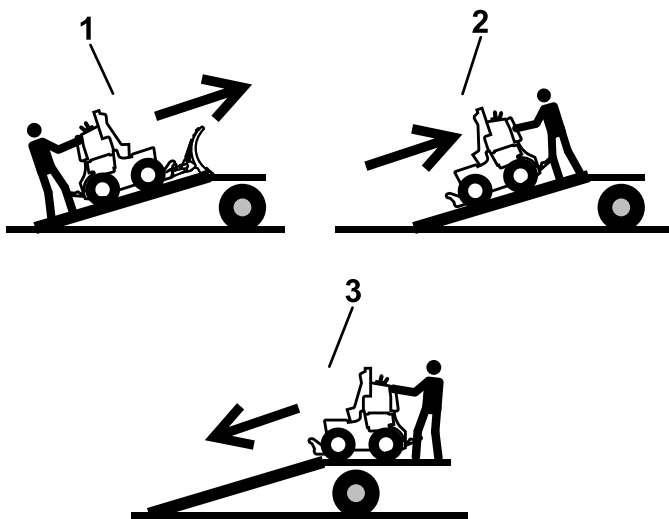


Figure 18

g387507

1. Walk the machine up the ramp if an attachment is installed.
2. Back the machine up the ramp if there is not an attachment installed.
3. Walk the machine forward off the ramp when unloading.

ropes. Refer to local regulations for tie-down requirements (Figure 19).

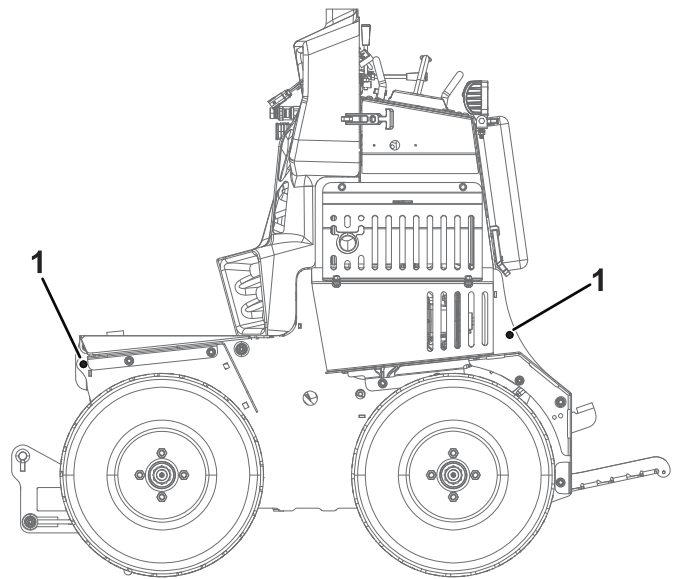


Figure 19

g381903

1. Tie down location

5. Lower the attachment, engage the parking brake, shut off the engine, and remove the key.
6. Tie down the machine near the front and rear wheels with straps, chains, cable, or



# Maintenance

**Note:** Determine the left and right sides of the machine from the normal operating position.

**Important:** Refer to your engine owner's manual for additional maintenance procedures.

## ⚠ WARNING

Failing to properly maintain the machine could result in premature failure of machine systems, causing possible harm to you or bystanders.

Keep the machine well maintained and in good working order as indicated in these instructions.

## Maintenance Safety

- Before adjusting, cleaning, servicing, or leaving the machine, do the following:
  - Park the machine on a level surface.
  - Lower the attachment.
  - Move the motion-control levers to the NEUTRAL position.
  - Wait for all moving parts to stop.
  - Engage the parking brake.
  - Remove the key.
  - Disconnect the spark-plug wire.
  - Allow machine components to cool before performing maintenance.
- Ensure that only trained personnel install and perform maintenance on the equipment and hydraulic components.
- Do not fill, calibrate, or clean the machine while people, especially children, or pets are in the area.
- Keep your hands and feet away from moving parts. If possible, do not make adjustments with the engine running.
- Carefully release pressure from components with stored energy.
- Check all fasteners at frequent intervals for proper tightness to ensure that the machine is in safe working condition.
- Never tamper with safety devices. Check their proper operation regularly.
- Clean up oil or fuel spills.
- Do not rely on a hydraulic system to support the machine; support the machine with jack stands whenever you raise the machine.
- Keep all parts in good working condition and all hydraulic fittings tight. Replace all worn, damaged, or missing parts and decals. Keep all fasteners tight to ensure that the machine is in safe working condition.
- To ensure optimum performance and continued safety of the machine, use only genuine BOSS replacement parts and accessories. Replacement parts and accessories made by other manufacturers could be dangerous, and such use could void the product warranty.

## Recommended Maintenance Schedule(s)

Maintenance Service Interval	Maintenance Procedure
After the first 50 hours	<ul style="list-style-type: none"><li>• Change the hydraulic filters and hydraulic fluid.</li></ul>
Before each use or daily	<ul style="list-style-type: none"><li>• Check the fuses.</li><li>• Check the hydraulic-fluid level.</li></ul>
After each use	<ul style="list-style-type: none"><li>• Clean the machine.</li></ul>
Every 50 hours	<ul style="list-style-type: none"><li>• Check the tire pressure.</li><li>• Check the hydraulic hoses and fittings for leaks.</li></ul>
Every 100 hours	<ul style="list-style-type: none"><li>• Check the battery.</li><li>• Check the belts.</li></ul>
Every 100 hours or yearly, whichever comes first	<ul style="list-style-type: none"><li>• Change the engine oil.</li><li>• Replace the inner air filter (more often in dirty or dusty conditions).</li></ul>
Every 150 hours	<ul style="list-style-type: none"><li>• Check the primary air filter (more often in dirty or dusty conditions).</li></ul>

Maintenance Service Interval	Maintenance Procedure
Every 200 hours	<ul style="list-style-type: none"> <li>• Replace the EFI fuel filter.</li> </ul>
Every 300 hours	<ul style="list-style-type: none"> <li>• Check and adjust the valve clearance. Contact an Authorized Service Dealer.</li> <li>• Replace the primary air filter (more often in dirty or dusty conditions).</li> <li>• Check the inner air filter (more often in dirty or dusty conditions).</li> </ul>
Every 500 hours	<ul style="list-style-type: none"> <li>• Replace and gap the spark plug.</li> <li>• Replace the traction-drive belt.</li> <li>• Change the hydraulic filters and hydraulic fluid.</li> </ul>
Before storage	<ul style="list-style-type: none"> <li>• Grease the quick pins.</li> <li>• Check the tire pressure.</li> <li>• Check and tighten all fasteners.</li> <li>• Lightly sand and use touch-up paint on painted areas that are scratched, chipped, or rusted.</li> <li>• Loosen the trip-return springs.</li> </ul>
Monthly	<ul style="list-style-type: none"> <li>• Check the wheel-lug nuts.</li> <li>• Check the hub castle-nut cotter pin.</li> </ul>

**Important:** Refer to your engine owner's manual for additional maintenance procedures.

## ***Pre-Maintenance Procedures***

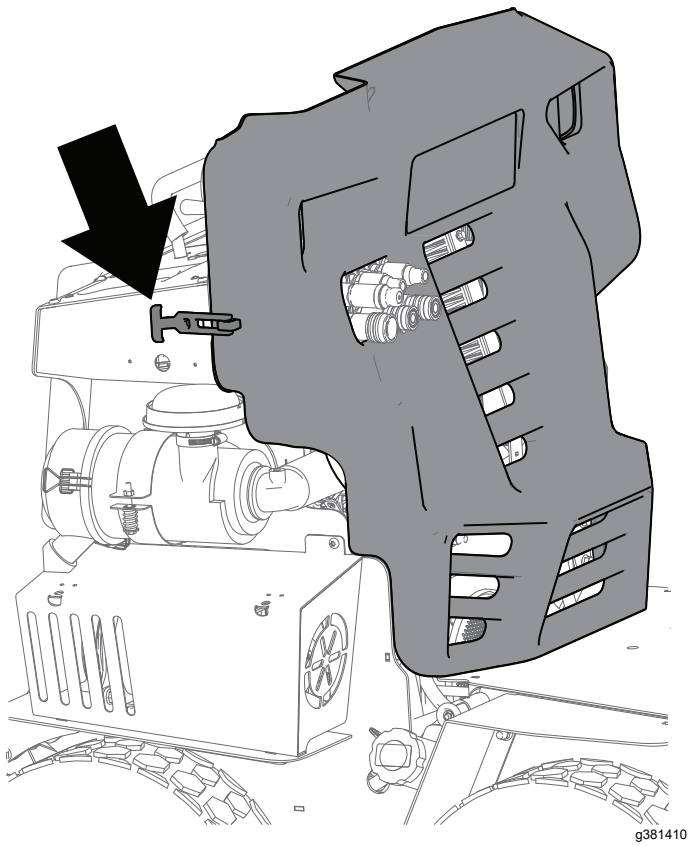
### **Preparing the Machine for Maintenance**

1. Park the machine on a level surface.
2. Lower the attachment.
3. Move the motion-control levers to the NEUTRAL position.
4. Wait for all moving parts to stop.
5. Engage the parking brake.
6. Remove the key.
7. Disconnect the spark-plug wire.
8. Allow machine components to cool.

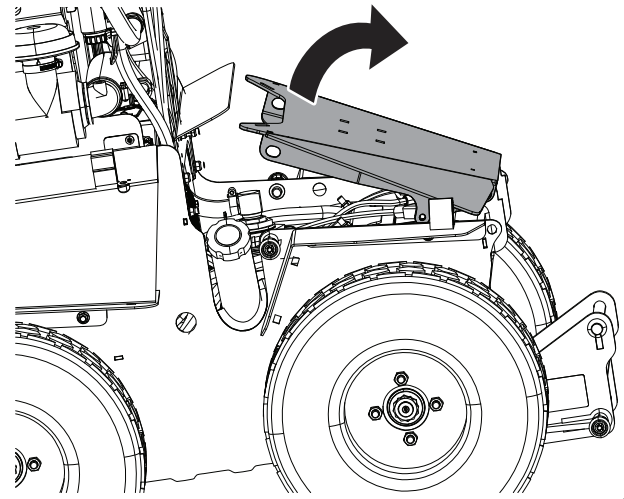
### **Opening the Machine Covers for Access**

If needed, remove the front plastic cover and raise the battery cover to obtain access to the battery and hydraulic tank.

1. Remove the front plastic cover ([Figure 20](#)).

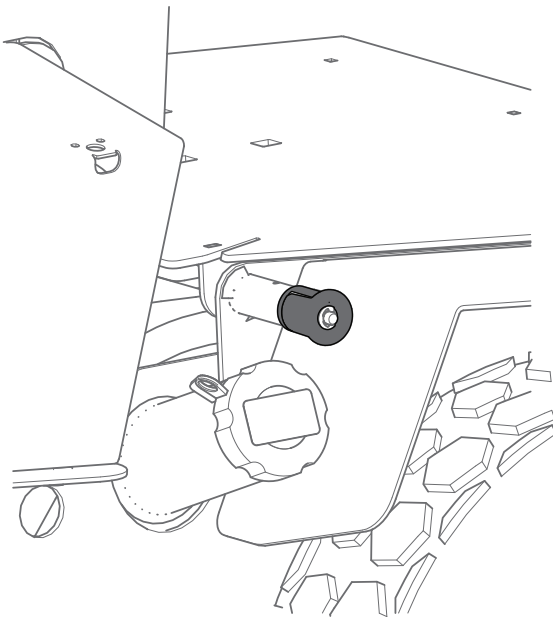


**Figure 20**



**Figure 22**

2. Release the quick pins to open the battery cover ([Figure 21](#) and [Figure 22](#)).



**Figure 21**

3. When you are finished performing maintenance, close the battery cover and secure with the quick pins.
4. Install the plastic cover; refer to [Installing the Plastic Cover \(page 8\)](#).

# Lubrication

## Greasing the Quick Pins

**Service Interval:** Before storage

**Grease type:** Aerosol penetrating oil

1. Spray aerosol penetrating oil into the top and bottom pin hole on each of the quick pins (Figure 23).

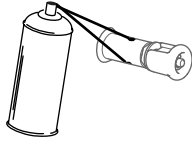


Figure 23

g387591

Refer to Figure 24 and Figure 25 to locate the quick pins.

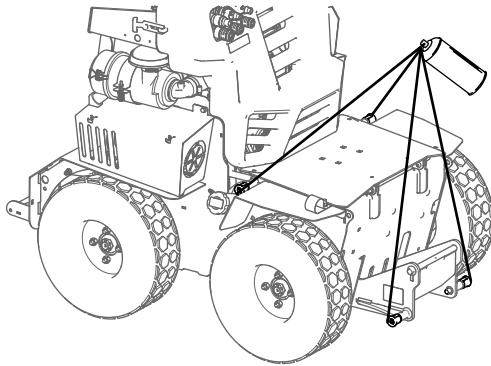


Figure 24

g387589

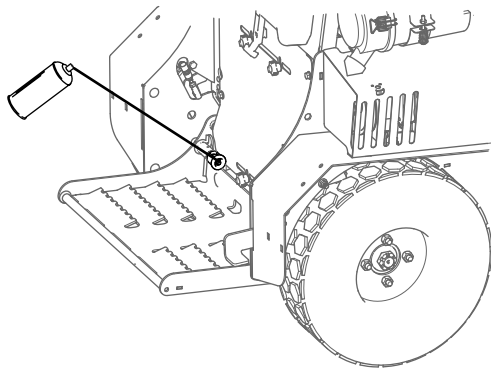


Figure 25

g387590

2. Wipe up any excess grease.

# Engine Maintenance

## Engine Safety

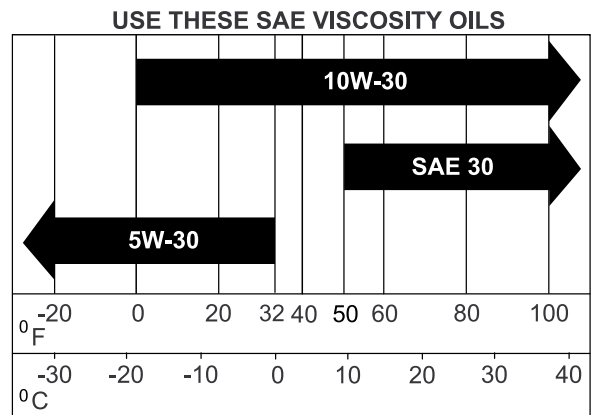
- Shut off the engine before checking the oil or adding oil to the crankcase.
- Keep your hands, feet, face, clothing, and other body parts away from the muffler and other hot surfaces.

## Servicing the Engine

**Service Interval:** Every 100 hours or yearly, whichever comes first

## Engine Oil Specifications

<b>Crankcase capacity:</b>	1.9 L (64 fl oz)
<b>Oil type:</b>	API classification SJ or later.
<b>Oil viscosity:</b>	Selected the oil viscosity according to ambient temperature in the table below.



g017552

g017552

Figure 26

## Servicing the Air Cleaner

Every 100 hours or yearly, whichever comes first—Replace the inner air filter (more often in dirty or dusty conditions).

Every 150 hours

Every 300 hours—Replace the primary air filter (more often in dirty or dusty conditions).

Every 300 hours—Check the inner air filter (more often in dirty or dusty conditions).

## Removing the Filters

1. Move the motion-control levers to the NEUTRAL position and engage the parking brake.

2. Shut off the engine, remove the key, and wait for all moving parts to stop before leaving the operating position.
3. Release the retaining clamps on the air cleaner and pull the air-cleaner cover off the air-cleaner body.

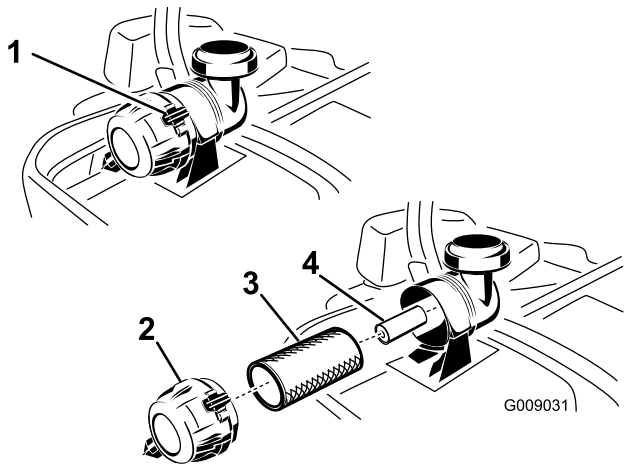


Figure 27

- |                       |                   |
|-----------------------|-------------------|
| 1. Air-cleaner clamps | 3. Primary filter |
| 2. Air-cleaner cover  | 4. Inner filter   |

4. Clean the inside of the air-cleaner cover with compressed air.
5. Gently slide the primary filter out of the air-cleaner body.

**Note:** Avoid knocking the filter into the side of the body.

6. Remove the inner filter only to replace it.

### Inspecting the Filters

1. Inspect the safety filter. If it is dirty, replace both the safety and primary filters.

**Important:** Do not attempt to clean the safety filter. If the safety filter is dirty, then the primary filter is damaged.

2. Inspect the primary filter for damage by looking into the filter while shining a bright light on the outside of the filter. If the primary filter is dirty, bent, or damaged, replace it.

**Note:** Holes in the filter appear as bright spots. Do not clean the primary filter.

### Installing the Filters

**Important:** To prevent engine damage, always operate the engine with both air filters and the cover installed.

1. If you are installing new filters, check each filter for shipping damage.

**Note:** Do not use a damaged filter.

2. If you are replacing the inner filter, carefully slide it into the filter body.
3. Carefully slide the primary filter over the safety filter.

**Note:** Ensure that the primary filter is fully seated by pushing on the outer rim while installing it.

**Important:** Do not press on the soft, inside area of the filter.

4. Install the air-cleaner cover with the breather cap down, and rotate so that the retaining clamps lock the cover in place.

### Checking the Engine Oil

1. Park the machine on a level surface, move the motion-control levers to the NEUTRAL position, engage the parking brake, and lower any attachments.
2. Shut off the engine, and remove the key. Allow the engine to cool.
3. Check the engine oil as shown below.

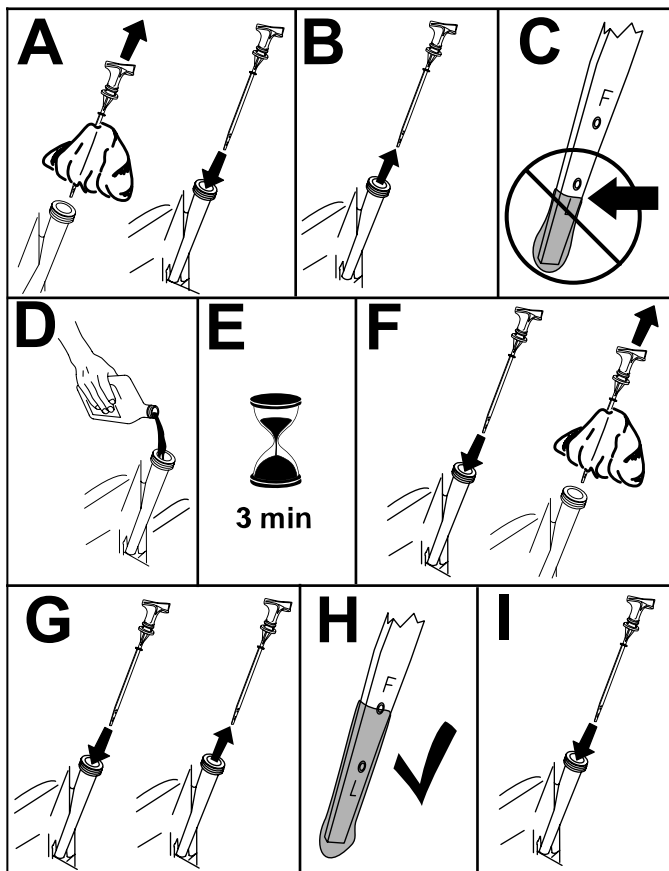


Figure 28

g388614

# Changing the Engine Oil

1. Remove the pad from the operator platform (Figure 29).

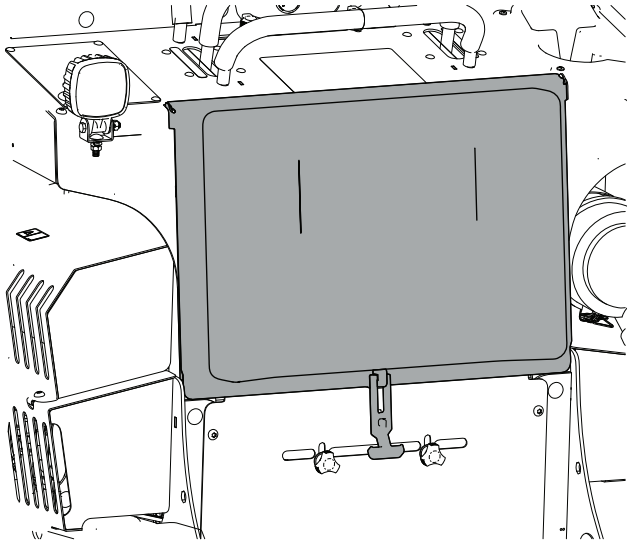


Figure 29

g382559

2. Remove the 4 bolts securing the access panel to the machine and remove the panel (Figure 30).

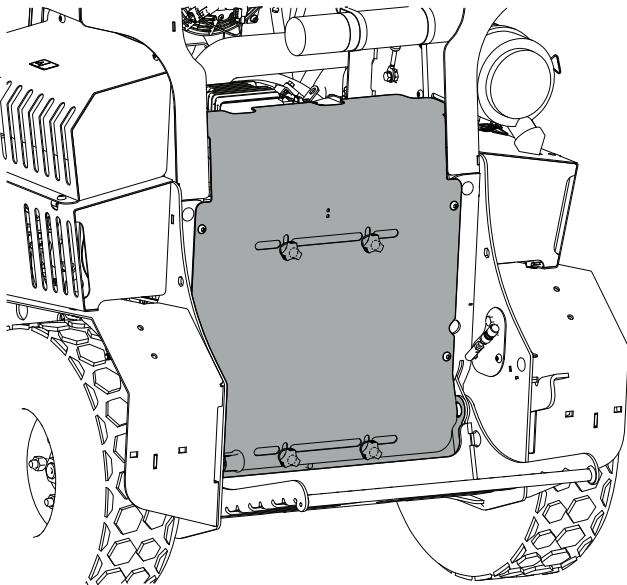


Figure 30

g382560

3. Locate the engine oil hose clamped in the storage position (Figure 31).

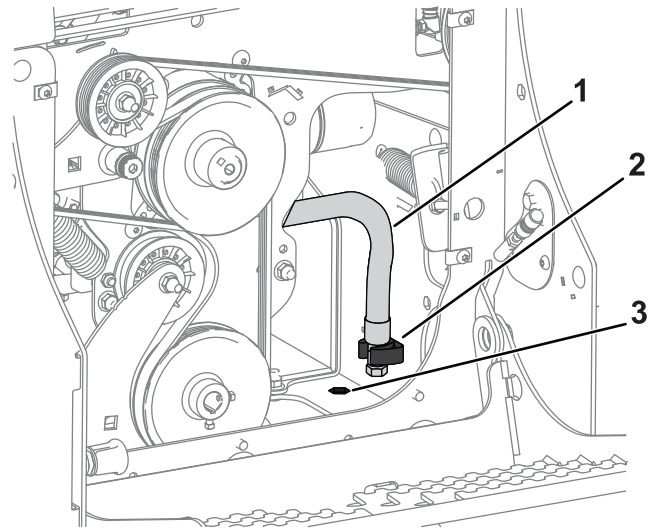


Figure 31

g382558

4. Place the hose in the hex hole in the frame of the machine (Figure 32).

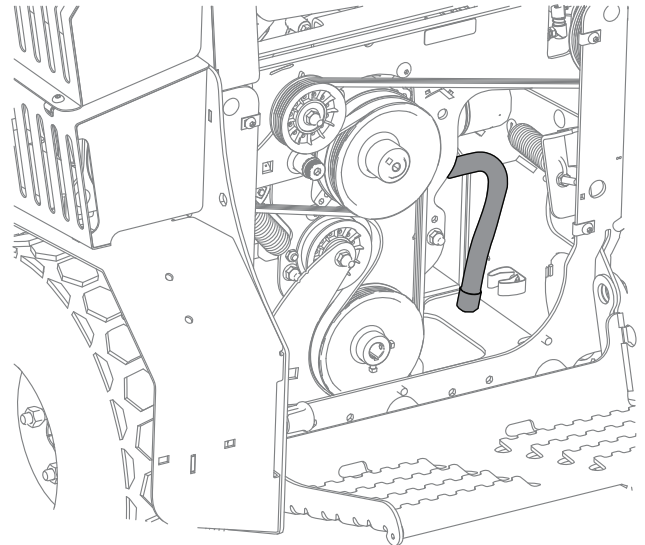


Figure 32

g382557

5. Place a container under the cap of the hose under the machine.
6. Remove the cap and drain the oil from the machine.
7. Place the cap back onto the hose and return the hose to the storage clamp.

**Important:** Ensure that the hose is in the storage position before operating the machine. If the hose is not stored, it could get damaged as the machine navigates the terrain.

8. Remove the oil fill cap on the engine (Figure 33).

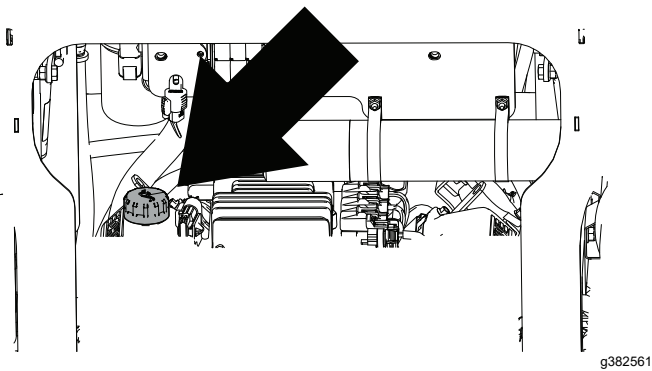


Figure 33

9. Slowly pour the new oil into the engine.

## Servicing the Spark Plug

**Service Interval:** Every 500 hours/Yearly (whichever comes first)

**Type for all Engines:** NGK BR6HS, Champion RTL86C, or equivalent

**Air Gap:** 0.76 mm (0.030 inch)

Ensure that the air gap between the center and side electrodes is correct before installing the spark plug.

Use a spark plug wrench for removing and installing the spark plug(s) and a gapping tool/feeler gauge to check and adjust the air gap. Install a new spark plug(s) if necessary.

## Removing the Spark Plug

1. Shut off the engine, engage the parking brake, remove the key, and wait for all moving parts to stop before leaving the operating position.
2. Remove the spark plug as shown in [Figure 34](#).

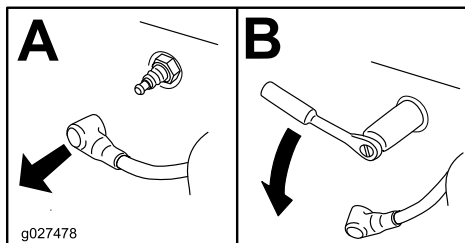


Figure 34

g027478

## Checking the Spark Plug

**Important:** Do not clean the spark plug(s). Always replace the spark plug(s) when it has a black coating, worn electrodes, an oily film, or cracks.

If you see light brown or gray on the insulator, the engine is operating properly. A black coating on the insulator usually means the air cleaner is dirty.

Set the gap to 0.75 mm (0.03 inch).

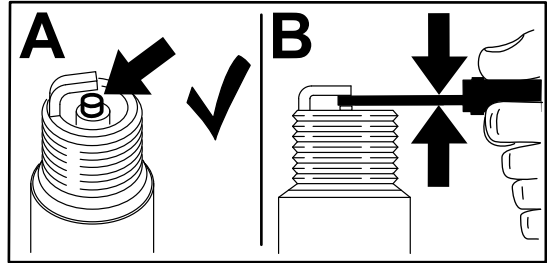


Figure 35

g206628

## Installing the Spark Plug

Tighten the spark plug(s) to 27 N·m (20 ft·lb).

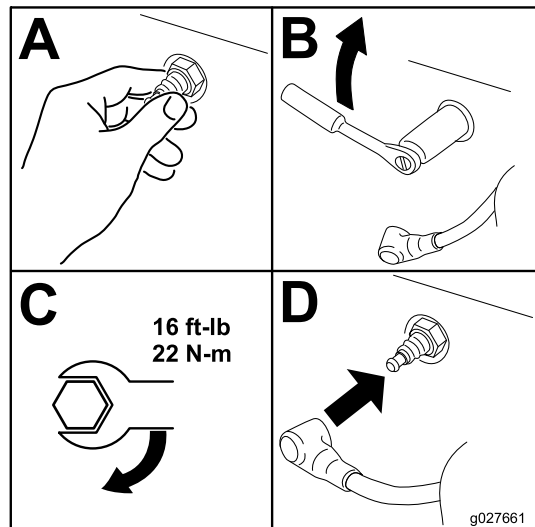


Figure 36

g027661



# Fuel System Maintenance

## Draining the Fuel Tank

**Note:** Use a syphon pump to drain fuel from the tank. You can purchase a syphon pump at a hardware store.

### **⚠ DANGER**

**In certain conditions, fuel is extremely flammable and highly explosive. A fire or explosion from fuel can burn you, others, and can damage property.**

- **Perform any fuel-related maintenance when the engine is cold. Do this outdoors in an open area. Wipe up any fuel that spills.**
  - **Never smoke when draining fuel, and stay away from an open flame or where a spark may ignite the fuel fumes.**
1. Park the machine on a level surface, move the motion-control levers to the NEUTRAL position, and engage the parking brake.
  2. Shut off the engine, remove the key, and wait for all moving parts to stop before leaving the operating position.
  3. Clean around the fuel cap to prevent debris from getting into the fuel tank.
  4. Remove the fuel cap.
  5. Insert a syphon pump into the fuel tank.
  6. Using the syphon pump, drain the fuel into a clean fuel can.
  7. Wipe up any spilled fuel.

# Electrical System Maintenance

## Electrical System Safety

- Disconnect the battery or remove the spark-plug wire before making any repairs. Disconnect the negative terminal first and the positive terminal last. Connect the positive terminal first and negative last.
- Charge the battery in an open, well-ventilated area, away from sparks and flames. Unplug the charger before connecting or disconnecting the battery. Wear protective clothing and use insulated tools.

## Servicing the Battery

**Service Interval:** Every 100 hours—Check the battery.

Always keep the battery clean and fully charged. Use a paper towel to clean the battery case. If the battery terminals are corroded, clean them with a solution of four parts water and 1 part baking soda. Apply a light coating of grease to the battery terminals to prevent corrosion.

Voltage: 12 V

## Removing the Battery

1. Remove the plastic cover and open the battery cover to obtain access to the battery; refer to [Opening the Machine Covers for Access \(page 18\)](#).
2. Disconnect the negative (black) ground cable from the battery post.

### **⚠ WARNING**

**Incorrect battery cable routing could damage the machine and cables, causing sparks. Sparks can cause the battery gases to explode, resulting in personal injury.**

- **Always disconnect the negative (black) battery cable before disconnecting the positive (red) cable.**
- **Always connect the positive (red) battery cable before connecting the negative (black) cable.**



## ⚠ WARNING

Battery terminals or metal tools could short against metal machine components, causing sparks. Sparks can cause the battery gases to explode, resulting in personal injury.

- When removing or installing the battery, do not allow the battery terminals to touch any metal parts of the machine.
- Do not allow metal tools to short between the battery terminals and metal parts of the machine.

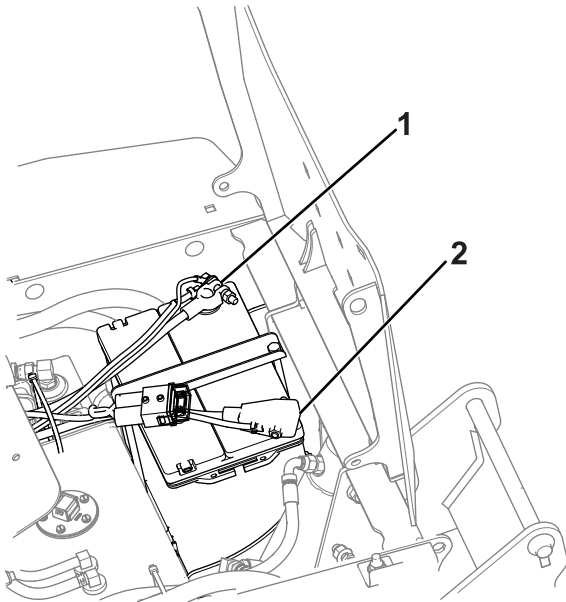


Figure 37

g387508

1. Negative (black)
2. Positive (red)

3. Remove the positive (red) battery cable.
4. Remove the battery.

## Charging the Battery

### ⚠ WARNING

Charging the battery produces gasses that can explode.

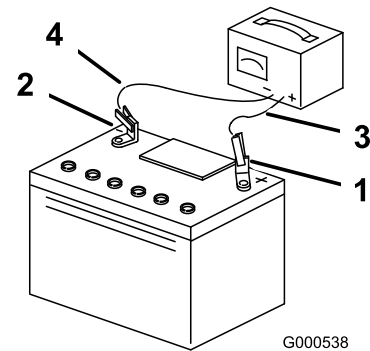
Never smoke near the battery and keep sparks and flames away from battery.

**Important:** Always keep the battery fully charged (1.265 specific gravity) to prevent battery damage when the temperature is below 0°C (32°F).

1. Remove the battery from the chassis; refer to [Removing the Battery \(page 24\)](#).

2. Check the electrolyte level.
3. Ensure that the filler caps are installed on the battery.
4. Charge battery for 10 to 15 minutes at 25 to 30 amps or 30 minutes at 10 amps.
5. When the battery is fully charged, unplug the charger from the electrical outlet, and disconnect the charger leads from the battery posts ([Figure 38](#)).
6. Install the battery onto the machine and connect the battery cables; refer to [Installing the Battery \(page 25\)](#).

**Note:** Do not run the machine with the battery disconnected; electrical damage may occur.



G000538

g000538

Figure 38

1. Positive battery post
2. Negative battery post
3. Red (+) charger lead
4. Black (-) charger lead

## Installing the Battery

### ⚠ WARNING

Incorrect battery cable routing could damage the machine and cables, causing sparks. Sparks can cause the battery gases to explode, resulting in personal injury.

- Always disconnect the negative (black) battery cable before disconnecting the positive (red) cable.
- Always connect the positive (red) battery cable before connecting the negative (black) cable.

## ⚠ WARNING

Battery terminals or metal tools could short against metal machine components, causing sparks. Sparks can cause the battery gases to explode, resulting in personal injury.

- When removing or installing the battery, do not allow the battery terminals to touch any metal parts of the machine.
- Do not allow metal tools to short between the battery terminals and metal parts of the machine.

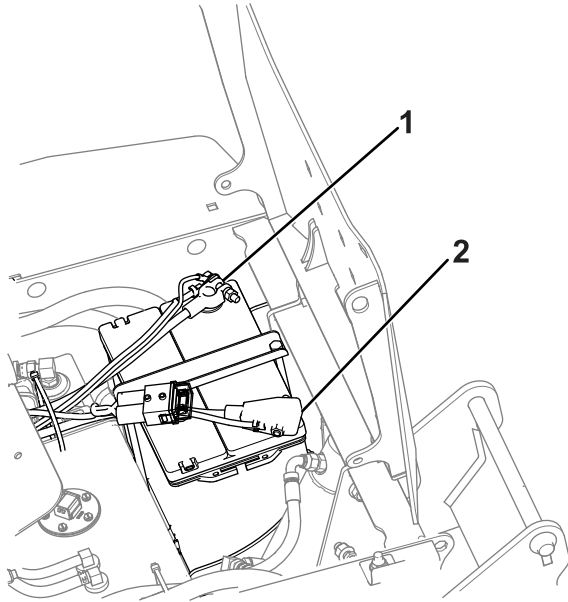


Figure 39

g387508

1. Negative (black)      2. Positive (red)

1. Place the battery on the machine.
2. Connect the 2 positive (red) battery cables.
3. Connect the 2 negative (black) battery cables.
4. Close the battery cover and secure with the quick pins.

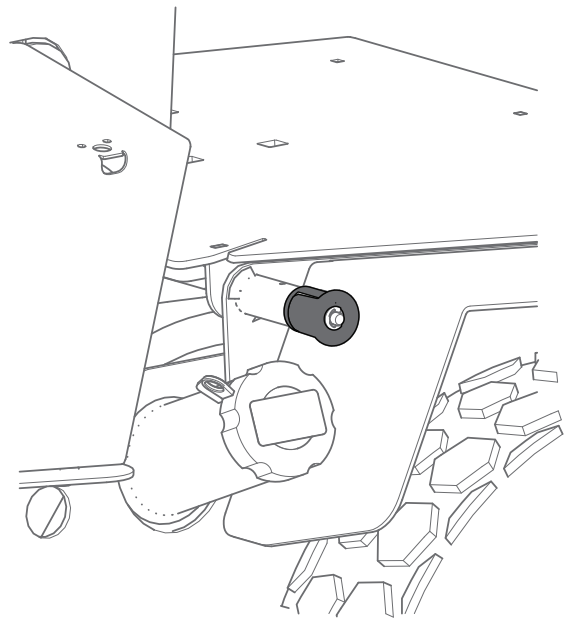


Figure 40

g386773

## Servicing the Fuses

The electrical system is protected by fuses. It requires no maintenance. If a fuse blows, check the component or circuit for a malfunction or short.

## Replacing the Main Fuse

There is 1 replaceable main fuse on the wire harness.

1. Remove the plastic cover and open the battery cover to obtain access to the main fuse; refer to [Opening the Machine Covers for Access \(page 18\)](#).
2. Locate the main fuse on the wire harness, near the battery, and remove the fuse cap ([Figure 41](#)).

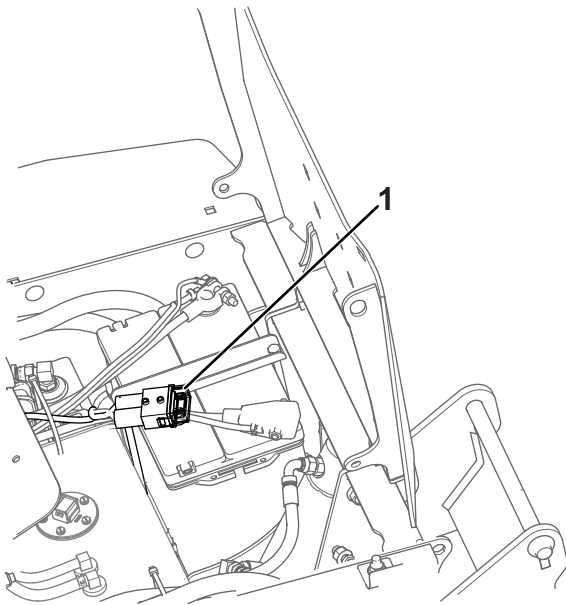


Figure 41

g387613

1. Main fuse

3. Remove and inspect the fuse.

If the fuse is burnt out, discard it and install a new fuse with the same rating.

**Important:** Do not use a fuse with a rating higher than the original fuse; serious damage to the electrical system or a fire could result.

4. Install the fuse cap, close the battery cover, and install the plastic cover.

## Replacing the Fuses in the Fuse Box

1. Remove the pad from the operator platform (Figure 42).

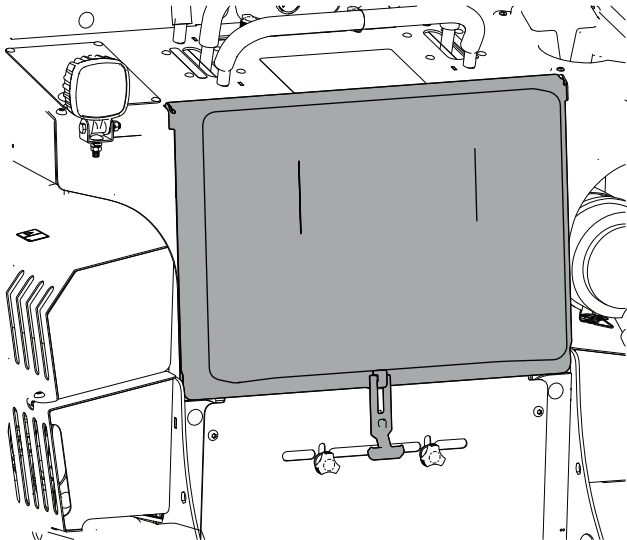


Figure 42

g382559

2. Remove the cover from the fuse box.

3. Remove and inspect the fuses.

If a fuse is burnt out, discard it and install a new fuse with the same rating.

**Important:** Do not use a fuse with a rating higher than the original fuse; serious damage to the electrical system or a fire could result.

4. Install the cover on the fuse box.

5. Install the pad on the operator platform.

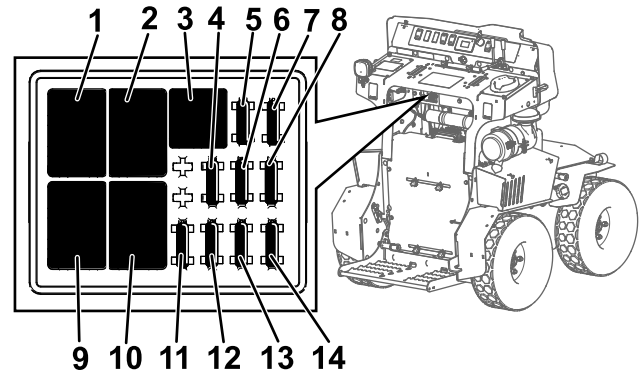


Figure 43

g387624

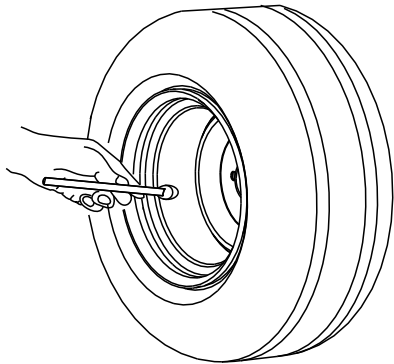
- |                      |                             |
|----------------------|-----------------------------|
| 1. Lights/aux        | 8. Spreader (30 A)          |
| 2. Cooling fan       | 9. Spreader controller      |
| 3. Engine run        | 10. Starter                 |
| 4. Engine run (15 A) | 11. Keyed power (15 A)      |
| 5. Aux 1 (10 A)      | 12. Lights (10 A)           |
| 6. Aux 2 (10 A)      | 13. 12 V power point (15 A) |
| 7. Fan (30 A)        | 14. Accessory (30 A)        |

# Drive System Maintenance

## Checking the Tire Pressure

**Service Interval:** Every 50 hours/Monthly (whichever comes first)—Check the tire pressure.

Maintain the air pressure in the tires at 124 kPa (18 psi).



G001055

Figure 44

g001055

---

## Checking the Wheel Fasteners

**Service Interval:** Monthly—Check the wheel-lug nuts.

Monthly—Check the hub castle-nut cotter pin.

Check and torque the wheel-lug nuts to 136 N·m (100 ft-lb).

Check the condition of the hub castle-nut cotter pin.

# Belt Maintenance

## Checking the Belts

**Service Interval:** Every 100 hours

Check the belts for cracks, frayed edges, burn marks, wear, signs of overheating, or any other damage.

## Replace the Traction-Drive and Auxiliary-Drive Belt

**Service Interval:** Every 500 hours/Every 2 years (whichever comes first)

1. Park the machine on a level surface, move the motion-control levers to the NEUTRAL position, engage the parking brake, and lower any attachments.
2. Shut off the engine, remove the key, and allow the engine to cool.
3. Remove the pad from the operator platform (Figure 45).

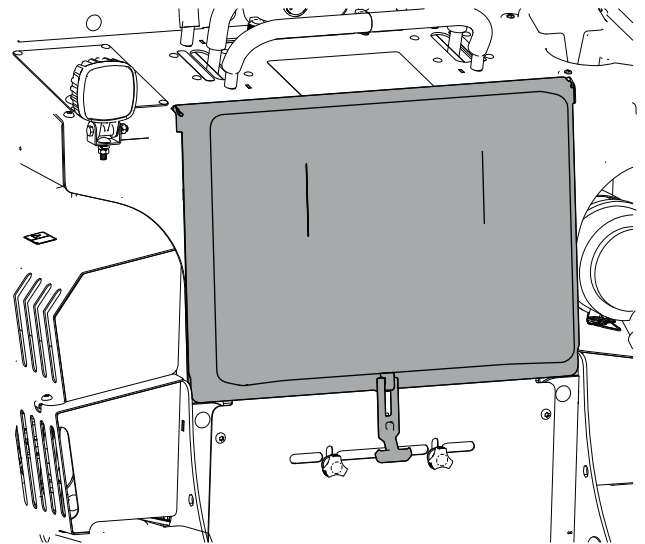
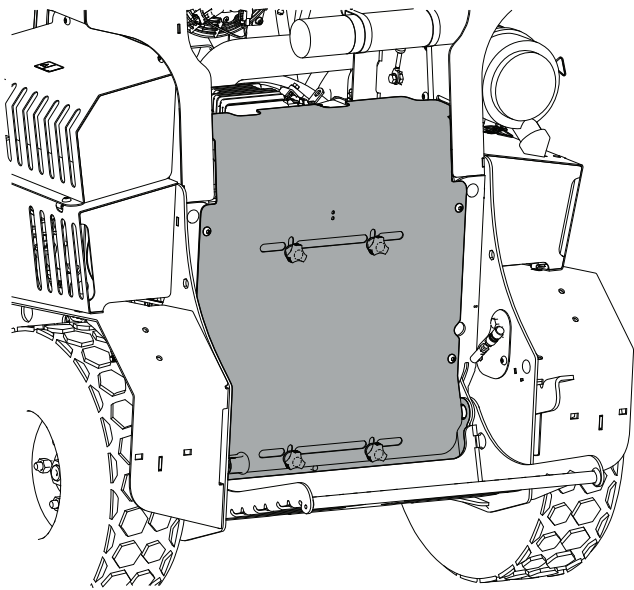


Figure 45

g382559

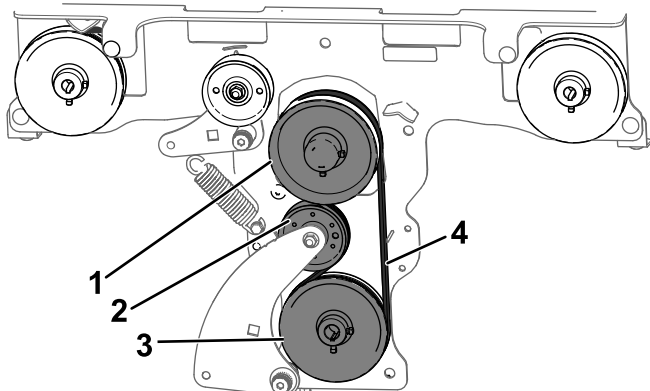
4. Remove the 4 bolts securing the access panel to the machine and remove the panel (Figure 46).



**Figure 46**

g382560

5. Remove the worn traction-drive belt.
6. Remove the worn auxiliary-drive belt.
7. Install a new auxiliary-drive belt around the pump pulley, then the tensioner pulley, and then the engine pulley. Refer to [Figure 47](#).

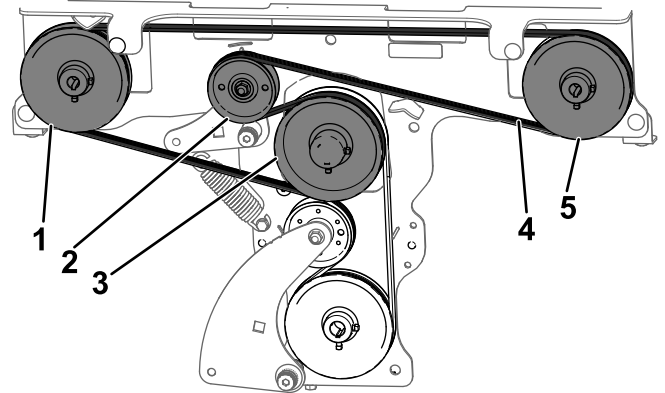


**Figure 47**

g387551

- |                     |                         |
|---------------------|-------------------------|
| 1. Engine pulley    | 3. Pump pulley          |
| 2. Tensioner pulley | 4. Auxiliary-drive belt |

8. Install a new traction-drive belt around the left-drive pulley, then the right-drive pulley, then the tensioner pulley, and then the engine pulley. Refer to [Figure 48](#).



**Figure 48**

g387538

- |                      |                        |
|----------------------|------------------------|
| 1. Left-drive pulley | 4. Traction-drive belt |
| 2. Tensioner pulley  | 5. Right-drive pulley  |
| 3. Engine pulley     |                        |

9. Install previously removed rear access panel with the corresponding bolts.
10. Install the previously removed pad on the operator's platform.

# Hydraulic System Maintenance

## Hydraulic System Safety

- Seek immediate medical attention if fluid is injected into skin. Injected fluid must be surgically removed within a few hours by a doctor.
- Ensure that all hydraulic-fluid hoses and lines are in good condition and all hydraulic connections and fittings are tight before applying pressure to the hydraulic system.
- Keep your body and hands away from pinhole leaks or nozzles that eject high-pressure hydraulic fluid.
- Use cardboard or paper to find hydraulic leaks.
- Safely relieve all pressure in the hydraulic system before performing any work on the hydraulic system.

## Hydraulic System Specifications

**Hydraulic Fluid Type:** BOSS Snowrator Hydraulic Fluid

**Hydraulic Tank Fluid Capacity:** 11 L (3 US gallons)

**Hydraulic System Fluid Capacity:** 15 L (4 US gallons)

**Important:** Use the fluid specified. Other fluids could damage the system.

## Checking the Hydraulic Fluid Level

**Service Interval:** Before each use or daily—Check the hydraulic-fluid level.

Every 50 hours—Check the hydraulic hoses and fittings for leaks.

**Note:** Check the hydraulic fluid level when the fluid is cold.

1. Park the machine on a level surface, move the motion-control levers to the NEUTRAL position, engage the parking brake, and lower any attachments.
2. Shut off the engine, remove the key, and allow the engine to cool.
3. Remove the plastic cover and open the battery cover to obtain access to the hydraulic fluid tank; refer to [Opening the Machine Covers for Access](#) (page 18).

4. Clean the area around the hydraulic tank breather/dipstick ([Figure 49](#)).

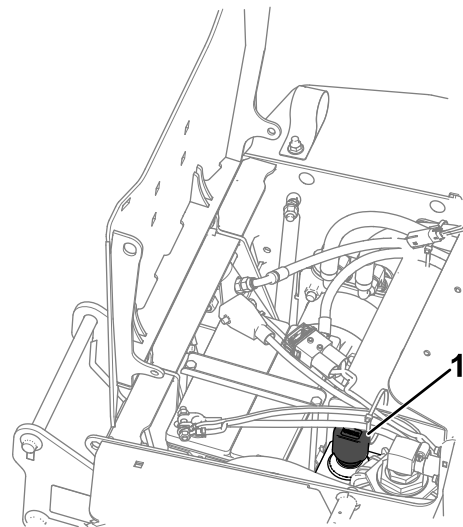


Figure 49

g387509

1. Hydraulic tank breather/dipstick

5. Check the hydraulic fluid as shown in [Figure 50](#).

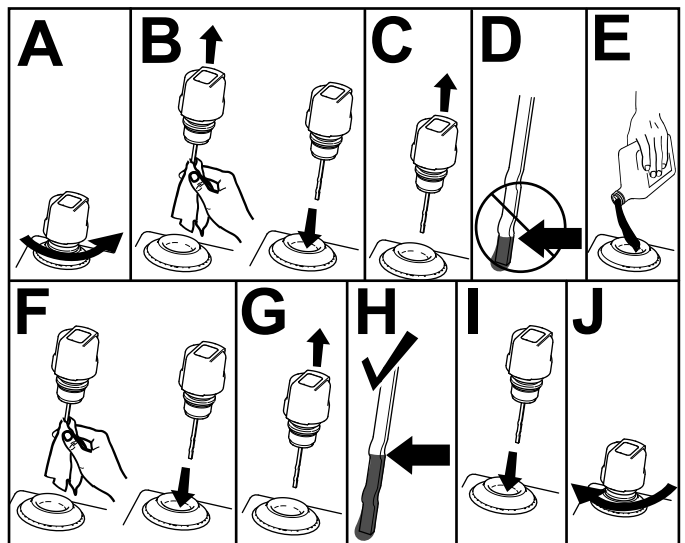


Figure 50

g387511

## Draining the Hydraulic Fluid and Replacing the Filters

**Service Interval:** After the first 50 hours—Change the hydraulic filters and hydraulic fluid.

Every 500 hours/Yearly (whichever comes first)—Change the hydraulic filters and hydraulic fluid.



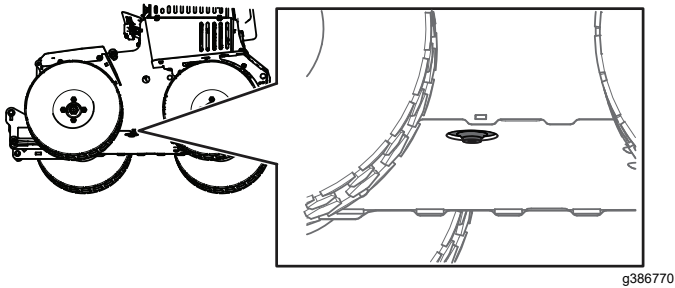
Change the hydraulic fluid more frequently in severe conditions. Contact your Authorized Service Dealer for a hydraulic kit to replace the hydraulic filters.

## **⚠ WARNING**

**Hot hydraulic fluid can cause severe burns.**

**Allow the hydraulic fluid to cool before performing any maintenance on the hydraulic system.**

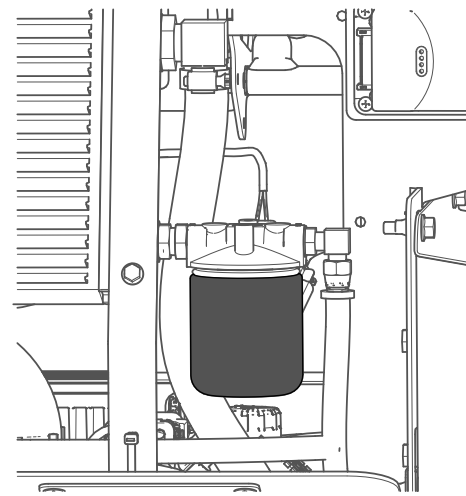
1. Park the machine on a level surface, move the motion-control levers to the NEUTRAL position, engage the parking brake, and lower any attachments.
2. Shut off the engine, remove the key, and allow the engine to cool.
3. Clean the area around the hydraulic reservoir plug ([Figure 51](#)).



**Figure 51**

g386770

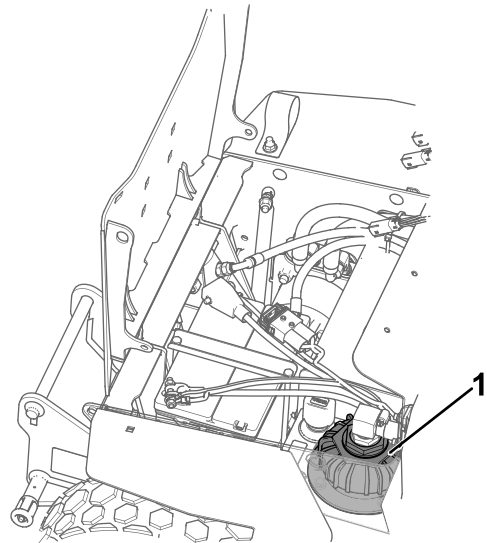
4. Place a drain pan under the hydraulic reservoir plug.
5. Remove the hydraulic reservoir plug.
6. Allow the hydraulic fluid to fully drain from the machine.
7. Remove the plastic cover and open the battery cover to obtain access to the hydraulic filters; refer to [Opening the Machine Covers for Access \(page 18\)](#).
8. Replace the small hydraulic filter as follows:
  - A. Locate and remove the small hydraulic filter ([Figure 52](#)).



**Figure 52**

g386771

- B. Install a new hydraulic filter.
9. Replace the large hydraulic filter inside of the hydraulic tank as follows:
    - A. Unscrew the hydraulic tank cap ([Figure 53](#)).



**Figure 53**

g387523

1. Hydraulic tank cap
  - B. Pull the filter retainer and filter out of the tank.
  - C. Remove and replace the filter on the filter retainer.
  - D. Screw the hydraulic tank cap onto the hydraulic tank.
10. Check the hydraulic fluid level; refer to [Checking the Hydraulic Fluid Level \(page 30\)](#).

# Cleaning

## Cleaning the Machine

**Service Interval:** After each use—Clean the machine.

Remove salt, sand, and grime from the external parts of the entire machine, especially the engine.

**Important:** You can wash the machine with a mild detergent and water. Do not pressure-wash the machine. Avoid excessive use of water, especially near the drive system and engine. Pressure-washing can force dirt and water into critical parts.

# Storage

## Storage Safety

- Let the engine cool before storing the machine.
- Do not store the machine or fuel near flames or drain the fuel indoors.

## Storing the Machine

1. Drive the machine to your storage location.
2. Remove salt, sand, and grime from the external parts of the entire machine, especially the engine.

**Important:** You can wash the machine with a mild detergent and water. Do not pressure-wash the machine. Avoid excessive use of water, especially near the drive system and engine. Pressure-washing can force dirt and water into critical parts.

3. Service the air cleaner.
4. Grease any exposed chrome or nitro bar on the hydraulic cylinders.
5. Apply dielectric grease to all of the wire-harness connectors and install the dust caps.
6. Change the engine oil..
7. Check the tire pressure.
8. Allow the engine to run until it shuts off. Repeat with the choke engaged (if applicable) until the engine does not start.
9. Dispose of extra fuel properly; recycle it according to local regulations.

**Important:** Do not store fuel containing stabilizer/conditioner longer than the duration recommended by the fuel-stabilizer manufacturer.

10. Remove the spark plug and check its condition.
11. With the spark plug removed from the engine, pour 15 ml (2 tablespoons) of engine oil into the spark-plug hole, and use the starter to crank the engine and distribute the oil inside the cylinder.
12. Install the spark plug but do not connect the wire to the spark plug.
13. Check and tighten all fasteners. Repair or replace any part that is damaged or missing.
14. Lightly sand and use touch-up paint on painted areas that are scratched, chipped, or rusted.
15. Store the machine in a clean, dry, garage or storage area. Remove the key from the engine key switch and store it in a memorable place. Cover the machine to protect it and keep it clean.



# Removing the Machine from Storage

1. Check the attachment for cracked welds.
2. Check the torque of all fasteners; tighten as necessary.
3. Check the hydraulic lines and hoses for cracks or leaks.
4. Replace the hydraulic fluid.
5. Lightly sand and use touch-up paint on painted areas that are scratched, chipped, or rusted.
6. Apply dielectric grease to all of the wire harness connectors.
7. Connect the spark plug wire.

# Troubleshooting

Problem	Possible Cause	Corrective Action
The engine does not start, starts hard, or fails to keep running.	<ol style="list-style-type: none"> <li>1. The fuel tank is empty or the shutoff valve is closed.</li> <li>2. The engine oil level is low.</li> <li>3. A spark-plug wire is loose or disconnected.</li> <li>4. A spark plug is pitted, fouled, or the gap is incorrect.</li> <li>5. The air filter is dirty.</li> <li>6. Dirt, water, or stale fuel is in the fuel system.</li> </ol>	<ol style="list-style-type: none"> <li>1. Fill the fuel tank with fuel and open the valve.</li> <li>2. Fill the engine with the recommended oil to the proper level.</li> <li>3. Install the spark-plug wire.</li> <li>4. Install a new, correctly gapped spark plug.</li> <li>5. Service the air filter.</li> <li>6. Contact an Authorized Service Dealer.</li> </ol>
The engine loses power.	<ol style="list-style-type: none"> <li>1. The engine load is excessive.</li> <li>2. The air filter is dirty.</li> <li>3. The oil level in the crankcase is low.</li> <li>4. A spark plug is pitted, fouled, or the gap is incorrect.</li> <li>5. Dirt, water, or stale fuel is in the fuel system.</li> <li>6. The fuel line is restricted.</li> <li>7. The hydraulic oil is over temperature.</li> </ol>	<ol style="list-style-type: none"> <li>1. Reduce the ground speed.</li> <li>2. Service the air filter.</li> <li>3. Add oil to the crankcase.</li> <li>4. Install a new, correctly gapped spark plug.</li> <li>5. Contact an Authorized Service Dealer.</li> <li>6. Clean the fuel filter and sediment cup.</li> <li>7. Reduce the load.</li> </ol>
The engine overheats.	<ol style="list-style-type: none"> <li>1. The engine load is excessive.</li> <li>2. The oil level in the crankcase is low.</li> <li>3. The blower housing is blocked.</li> </ol>	<ol style="list-style-type: none"> <li>1. Reduce the ground speed.</li> <li>2. Add oil to the crankcase.</li> <li>3. Shut off the machine, wait for all moving parts to stop, remove the key, and clean debris from the blower housing.</li> </ol>
The machine does not drive.	<ol style="list-style-type: none"> <li>1. The hydraulic-fluid reservoir is low.</li> <li>2. Air is in the hydraulic system.</li> <li>3. The pump-bypass valves are open.</li> <li>4. A drive belt fell off or broke.</li> </ol>	<ol style="list-style-type: none"> <li>1. Add hydraulic fluid to the reservoir.</li> <li>2. Let the machine sit and idle for 1 minute to self-prime.</li> <li>3. Tighten the bypass valves. Torque to 12 to 15 N·m (9 to 11 ft-lb).</li> <li>4. Replace the drive belt.</li> </ol>
Fluid leaks from the lift cylinders.	<ol style="list-style-type: none"> <li>1. The fittings are loose or the O-rings are damaged.</li> <li>2. The rods are pitted or rough.</li> </ol>	<ol style="list-style-type: none"> <li>1. Tighten loose fittings. See your authorized BOSS dealer for a seal kit.</li> <li>2. Polish them with a copus cloth or extra fine steel wool.</li> </ol>
Fluid is running out of the fill cap of the hydraulic-fluid tank.	<ol style="list-style-type: none"> <li>1. The terrain is too steep.</li> <li>2. The tank is overfilled.</li> <li>3. The plow is hitting snowbanks too hard.</li> </ol>	<ol style="list-style-type: none"> <li>1. Avoid steeply sloped areas.</li> <li>2. The hydraulic fluid level should be within 3/4 of the top of the reservoir.</li> <li>3. Do not plow recklessly.</li> </ol>

**Notes:**

**BOSS**  
S N O W P L O W