

The GeoStone system utilizes a procedure called "**HALF-WHOLE**" for a corner instead of a corner block. This insures there will always be enough corners for a project and the corners will ALWAYS be from the same run. These are two things that are constantly an issue with traditional corner block. This procedure also creates an interlocking corner, adding power and stability to an otherwise weak point in the wall. Each corner requires 1.5 block per course/corner. Cuts will be made with a diamond blade rescue or table saw prior to making the split on the "half side". Precise measurements and cuts are important for alignment and to minimize waste.

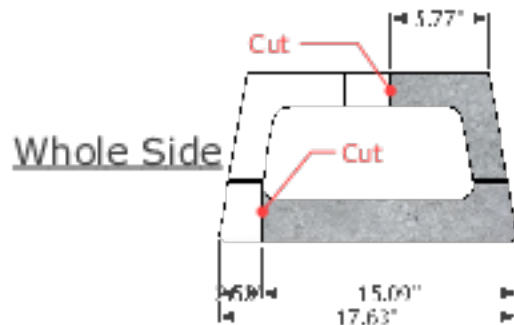

A paver splitter is best for getting the rough texture on the "half side" to match the face of the block. Cutting the back portion off allows the 8" block to be "fed" into the splitter sideways and on the face. There will be two "half sides". One side will be used in the first course of the corner, the 2nd will be used in the next course. This procedure requires 1.5 blocks per corner.

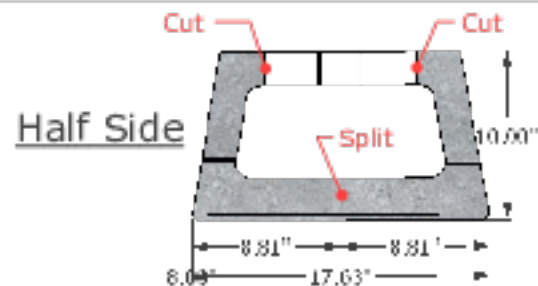
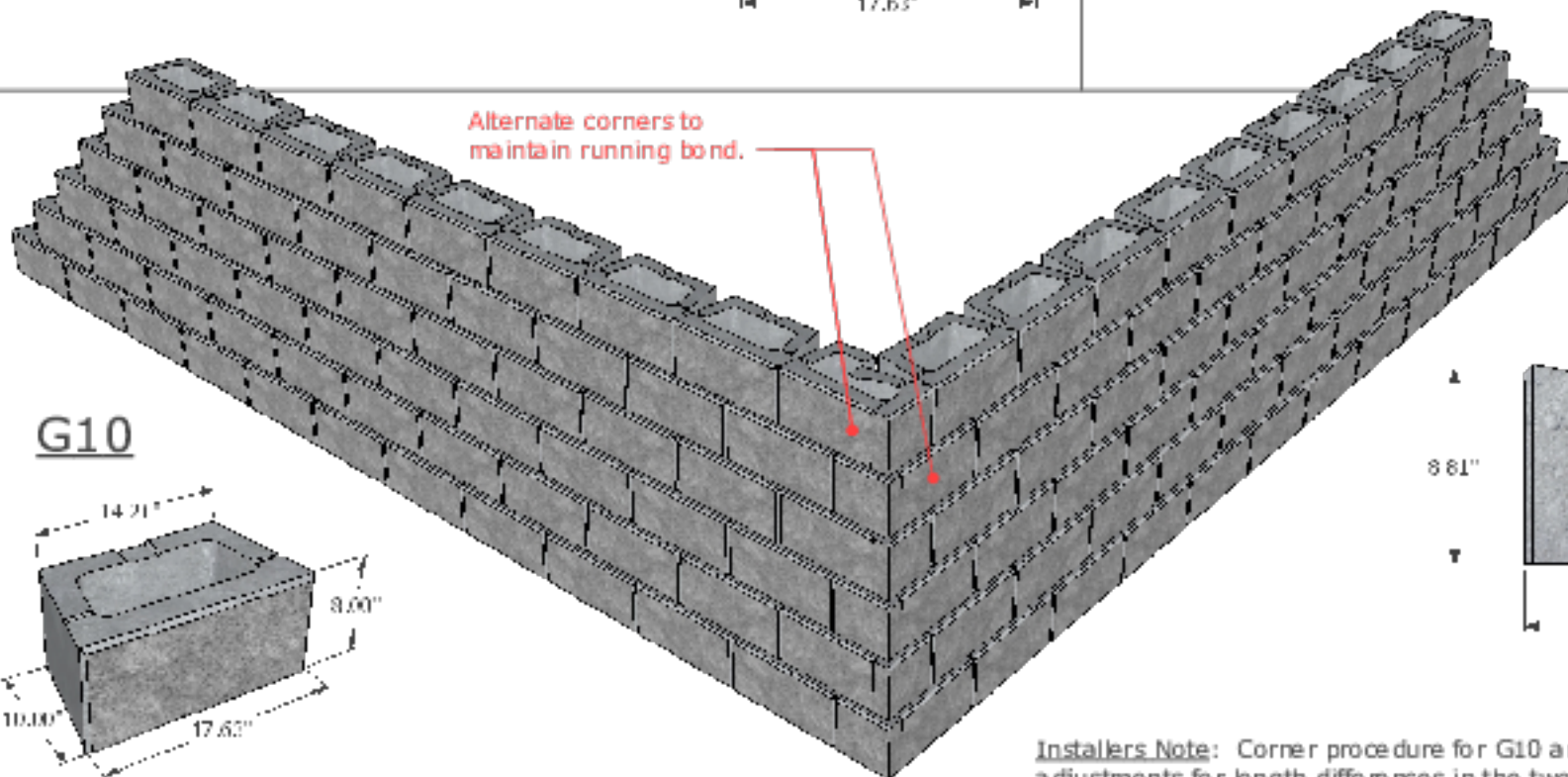
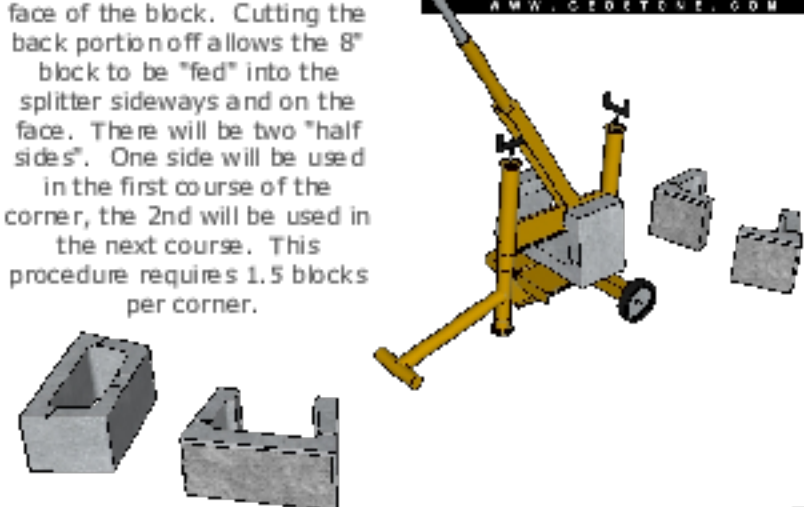

**G10**

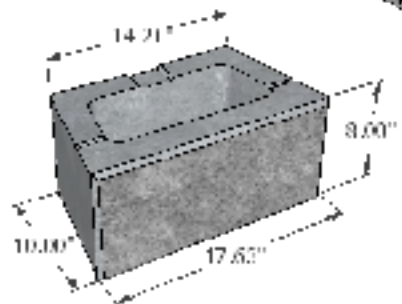

Finished Corner  
Top View

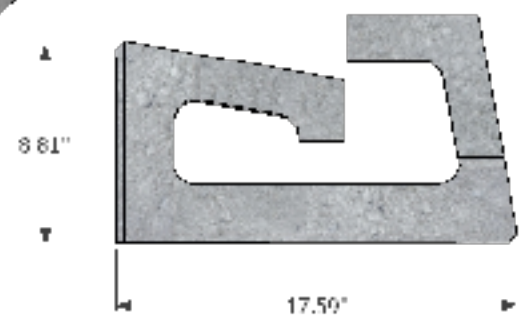

**Installers Note:** Corner procedure for G10 and G12-8 is similar. Make adjustments for length differences in the two lines and cut/split accordingly.