



SERVICE PARTS LIST

BULLETIN NO.
54-49-2715

SPECIFY CATALOG NO. AND SERIAL NO. WHEN ORDERING PARTS		REVISED BULLETIN	DATE
M18™ Brushless String Trimmer			Jan. 2026
CATALOG NO. 2828-20	SERIAL NO. L66A	WIRING INSTRUCTION See Page 2	

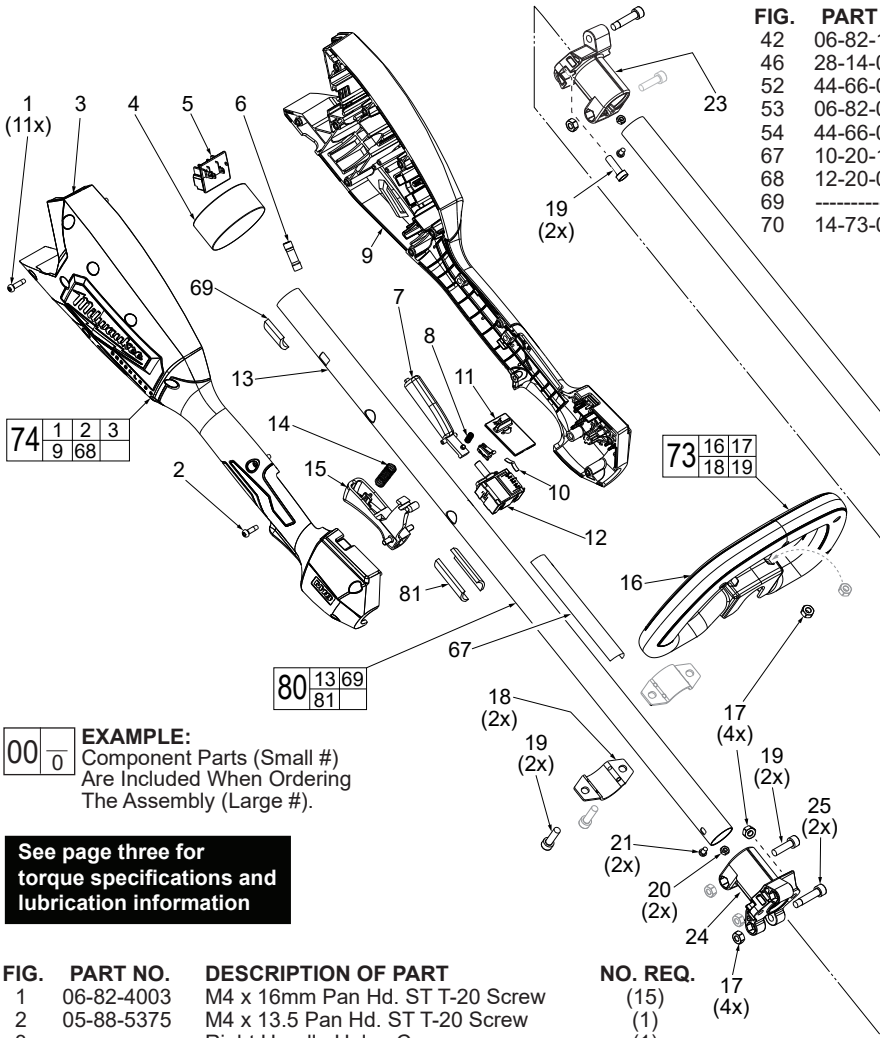

FIG.	PART NO.	DESCRIPTION OF PART	NO. REQ.
42	06-82-1080	M3 x 14mm Pan Hd. ST T-10 Screw	(4)
46	28-14-0047	Gearcase	(1)
52	44-66-0108	Bearing Plate	(1)
53	06-82-0029	M5 x 16mm Pan Hd. ST T-25 Screw	(5)
54	44-66-0109	Lock Plate	(1)
67	10-20-1781	Warning Label	(1)
68	12-20-0417	Service Nameplate (Not Shown)	(1)
69	-----	Rubber Foam Piece	(1)
70	14-73-0016	Spindle/Gear Assembly	(1)

74	1	2	3
	9	68	

73	16	17
	18	19

80	13	69
	81	

EXAMPLE:
Component Parts (Small #)
Are Included When Ordering
The Assembly (Large #).

**See page three for
torque specifications and
lubrication information**

FIG.	PART NO.	DESCRIPTION OF PART	NO. REQ.
1	06-82-4003	M4 x 16mm Pan Hd. ST T-20 Screw	(15)
2	05-88-5375	M4 x 13.5 Pan Hd. ST T-20 Screw	(1)
3	-----	Right Handle Halve-Cover	(1)
4	42-87-0027	Counter Balance	(1)
5	-----	Battery Terminal Block	(1)
6	22-56-0006	Wire Connector	(1)
7	45-72-0084	Release Trigger	(1)
8	40-50-0373	Spring	(1)
9	-----	Left Handle Halve-Support	(1)
10	40-50-0027	Spring Plate	(1)
11	45-24-0052	Speed Selector	(1)
12	-----	Switch Assembly	(1)
13	45-08-0043	Rear Tube	(1)
14	40-50-0374	Trigger Spring	(1)
15	45-72-0083	On-Off Trigger	(1)
16	-----	Carrier Handle	(1)
17	05-55-0006	M6 Hex Nut	(8)
18	42-68-0292	Carrier Handle Clip	(2)
19	05-74-0015	M6 x 21.5mm, 5mm Hex Socket Cap Screw	(6)
20	05-55-0004	M4 Hex Nut	(2)
21	06-82-0178	M4 x 5.6mm Pan Hd. T-20 Mach. w/ Nyloc	(2)
23	42-90-0109	Front Coupler	(1)
24	42-90-0111	Rear Coupler	(1)
25	05-74-0083	M6 x 28.5mm Cap Hd. T-30 Mach. Screw	(2)
26	45-08-0106	Front Tube	(1)
27	-----	String Guard	(1)
28	06-82-0247	M6 x 16mm Pan Hd. ST T-30 Screw	(4)
29	42-26-0024	Line Cut-Off Blade	(1)
30	05-78-0032	M5 X 13mm Pan Hd. T-25 Machine Screw	(2)
31	44-66-0226	Clamping Plate	(1)
32	06-82-0152	M5 x 22mm Pan Hd. ST T-25 Screw	(4)
33	-----	Motor Housing-Left	(1)
34	45-03-0013	Metal Mesh	(2)
35	-----	PCBA w/ Stator	(1)
41	-----	Motor Housing-Right	(1)

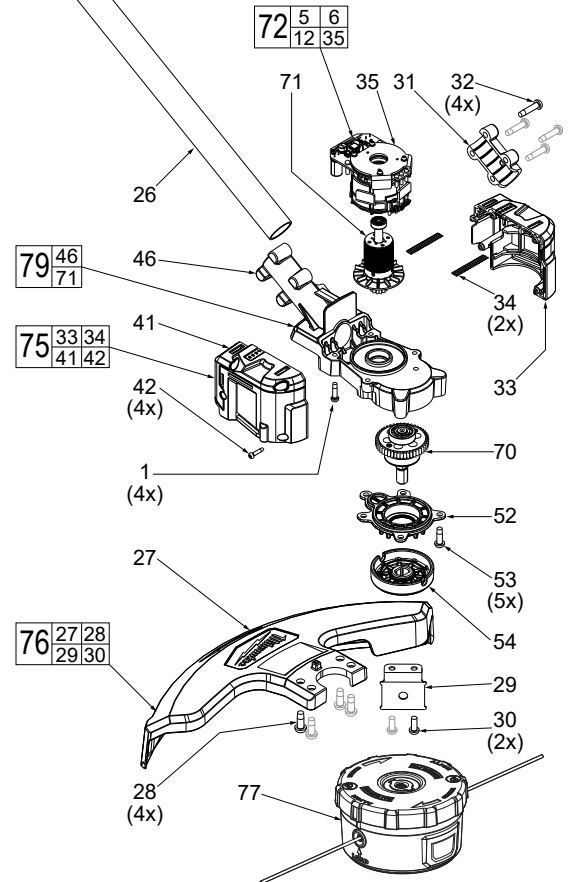

79	46	71
----	----	----

75	33	34
	41	42

76	27	28
	29	30

72	5	6
	12	35

FIG.	PART NO.	DESCRIPTION OF PART	NO. REQ.
71	16-01-0046	Rotor Assembly	(1)
72	14-20-0226	Electronic Assembly	(1)
73	14-34-0126	Carrier Handle Assembly	(1)
74	14-38-0137	Handle Service Kit	(1)
75	31-50-0142	Motor Housing Service Kit	(1)
76	14-32-0119	String Guard Assembly	(1)
77	49-16-2748	Loaded Replacement Head	(1)
78	49-96-0055	Torx Key Wrench (Not Shown)	(1)
79	14-30-0059	Gearcase Kit	(1)
80	14-46-0208	Rear Tube Kit	(1)
81	-----	Rubber Foam Pad	(2)

MILWAUKEE TOOL • www.milwaukeetool.com
13135 W. LISBON RD., BROOKFIELD, WI 53005

For replacing Electronic Assembly, carefully cut/remove heat shrink tubing from wires and terminals. The following wires need to be unsoldered from the battery terminals:

- 26 AWG Red to B+.
- 26 AWG Green to DC.
- 26 AWG Blue to DP.
- 12 AWG Black to B-.

The 12 AWG Blue B+SW wire is crimped to the Blue wire coming from the switch.

The 5 pin connector for remaining signal wires just need to be connected back together.

Be sure to install heat shrink tubing over wires prior to resoldering. After soldering, cover wires and terminals and shrink with heat gun.

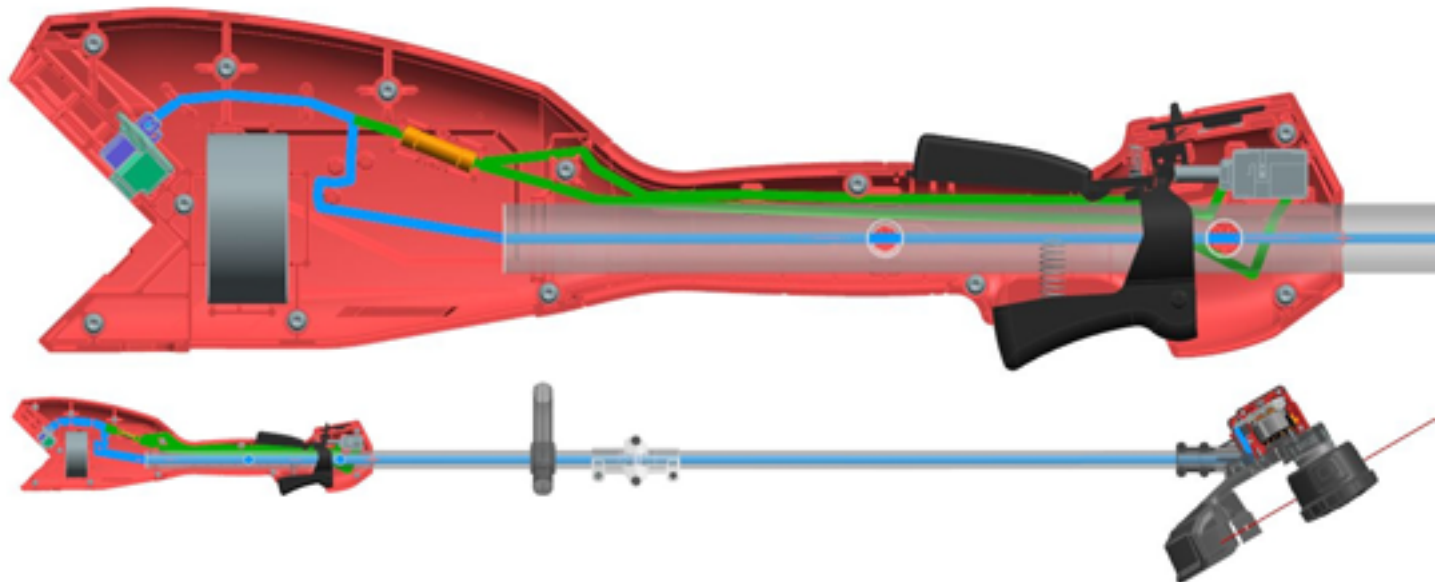
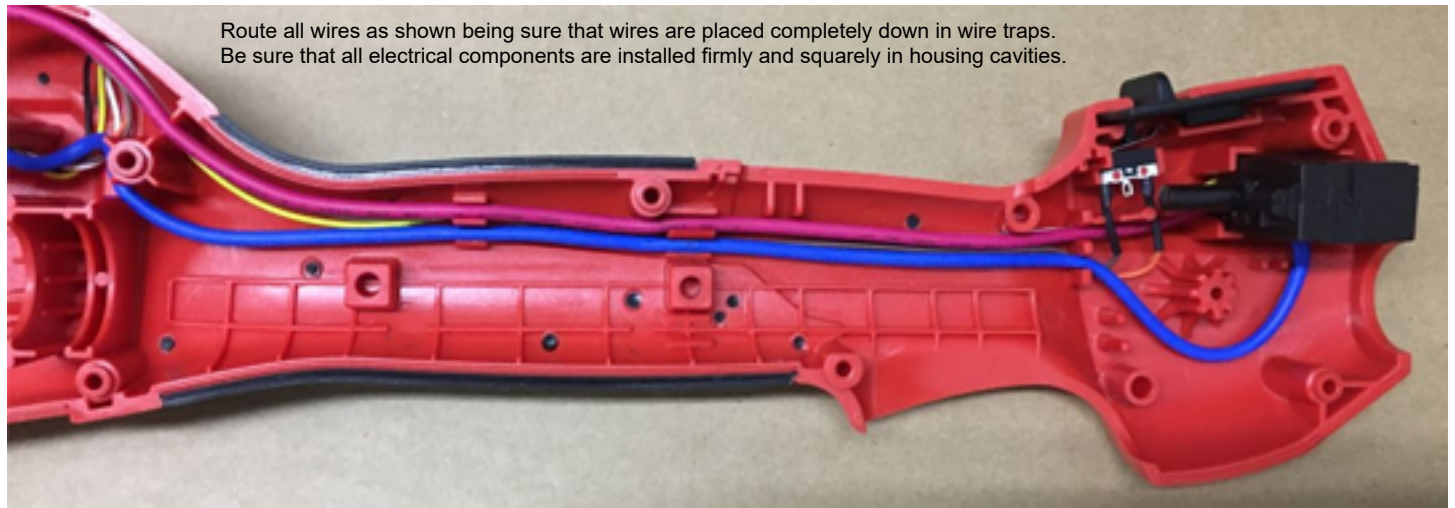
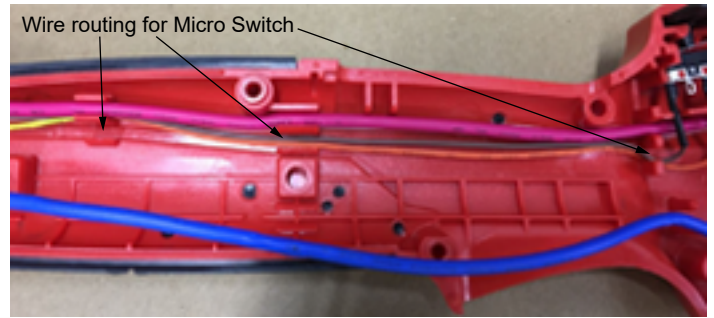
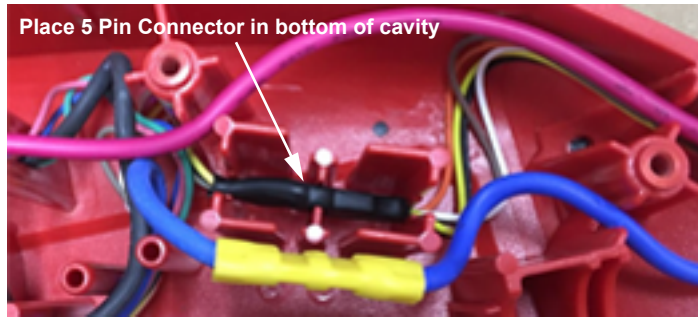
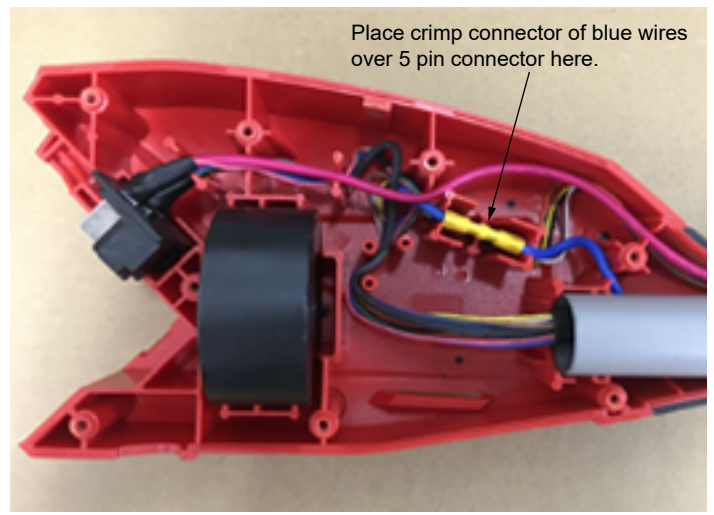

SCREW TORQUE SPECIFICATIONS

FIG.	PART NO.	WHERE USED	SEAT TORQUE	
			(kgf-cm)	(lb-in)
1	06-82-4003	Handle Halve-Cover	9-11	8-9
1	06-82-4003	Gearcase	16-19	14-16
2	05-88-5375	Handle Halve-Cover	9-11	8-9
19	05-74-0015	Carrier Handle	30-35	26-30
19	05-74-0015	Rear Coupler	20-25	17-21
19	05-74-0015	Front Coupler	20-25	17-21
21	05-81-0166	Rear Tube	10-14	8-12
25	05-74-0083	Rear Coupler	28-30	24-26
28	06-82-0247	String Guard	30-35	26-30
30	05-88-0032	Line Cut-Off Blade	20-24	17-20
32	06-82-0152	Clamping Plate	25-28	21-24
42	06-82-1080	Motor Housing-Right	8-10	7-8
53	06-82-0029	Bearing Plate	21-25	18-21

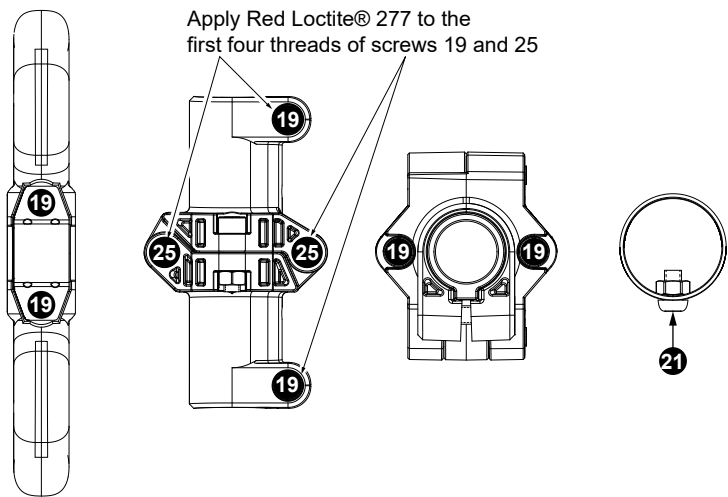
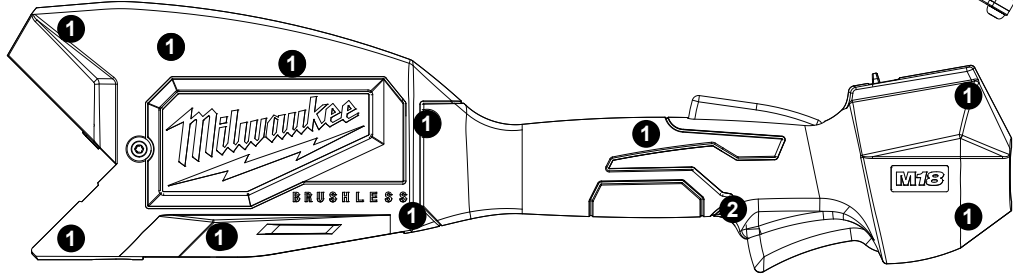
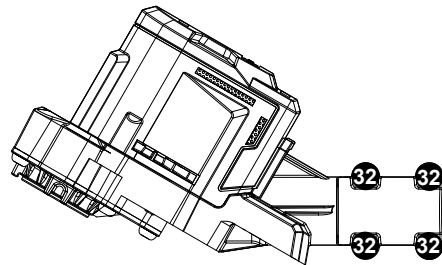
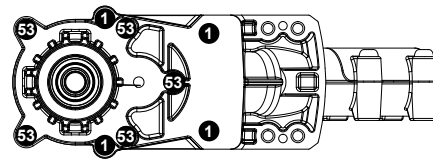

Apply Red Loctite® 277 to the first four threads of screws 19 and 25

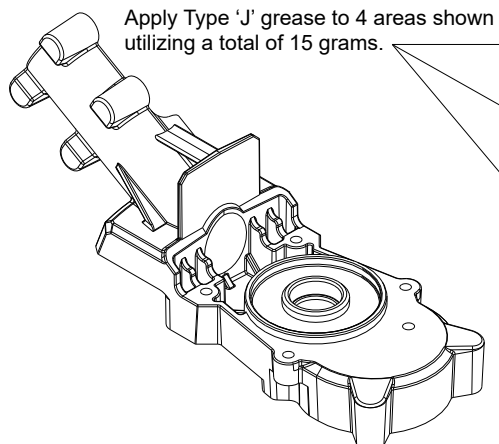
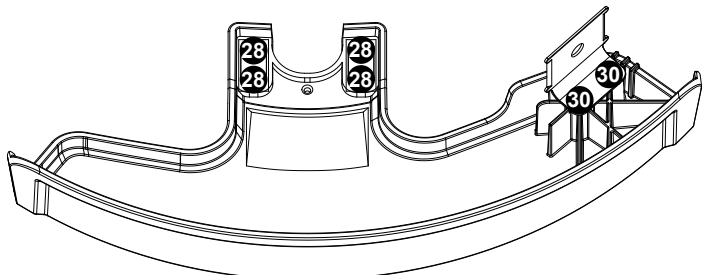
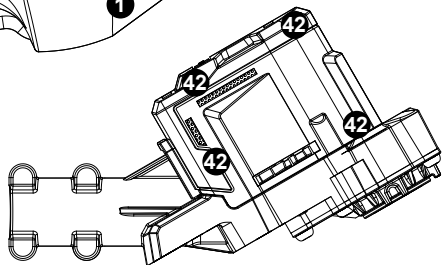

Apply Type 'J' grease to 4 areas shown utilizing a total of 15 grams.

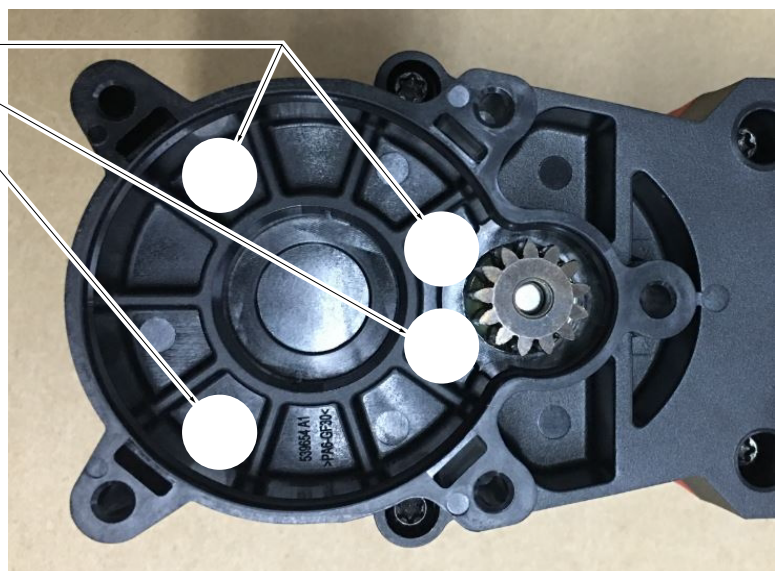

LUBRICATION

Use Type 'J' Grease, No. 49-08-4220 (16 oz. tub)

NOTE: When servicing, remove 90-95% of the existing grease prior to installing Type 'J'. Original grease may be similar in color but not compatible with 'J'. Clean gear assemblies with a clean, dry cloth.