

# Installation Manual

## Self-Contained Hopper Spreaders Carbon & Stainless Steel Models

This manual applies to the following models:

72" Spreaders (serial numbers 1200 and above)

96" Spreaders (serial numbers 4884 and above)

120" Spreaders (serial numbers 1000 and above)

### Table of Contents

Warranty Information .....	1
General Information .....	1
Safety Precautions .....	2
Installation Instructions .....	3
Spreader Operation .....	4
Spreader Maintenance.....	6
Repair Parts & Drawings .....	8



### Spreader Models and Specifications

Model #	Hopper Length	Material	Chute Length	Overall Length	Overall Width	Overall Height	Empty Weight	Cap.
SCH072SS	6'	Stainless	Standard	91¾"	47" *	32½"	639#	1.5
SCH072SSX	6'	Stainless	Extended	91¾"	47" *	32½"	655#	1.5
SCH096C	8'	Carbon	Standard	115¾"	47" *	32½"	857#	2.0
SCH096CX	8'	Carbon	Extended	115¾"	47" *	32½"	875#	2.0
SCH096SS	8'	Stainless	Standard	115¾"	47" *	32½"	745#	2.0
SCH096SSX	8'	Stainless	Extended	115¾"	47" *	32½"	758#	2.0
SCH120SS	10'	Stainless	Standard	139¾"	47"	32½"	789#	2.5
SCH120SSX	10'	Stainless	Extended	139¾"	47"	32½"	804#	2.5

\* 6' spreaders – Serial numbers 1404 and below – Overall Width = 50¾"

\* 8' spreaders – Serial numbers 5934 and below – Overall Width = 50¾"

### SPREADER WARRANTY

This warranty replaces all previous warranties and no employee of this company is authorized to extend additional warranties, or agreements, or implications not explicitly covered herein.

Buyers Products Company warrants all parts of the product to be free from defects in material and workmanship for a period of one (1) year, excluding the gasoline engine, from the date of installation. Parts must be properly installed and used under normal conditions. Normal wear is excluded.

Any part which has been altered, including modifications, misuse, accident, or lack of maintenance will not be considered under this warranty.

The sole responsibility of Buyers Products Company under this warranty is limited to repairing or replacing any part(s) which are returned, prepaid, 30 days after such defect is discovered, and returned part(s) are found to be defective by Buyers Products Company.

Authorization from Buyers Products Company must be obtained before returning any part. The following information must accompany defective parts returned to Buyers Products Company: RMA#, spreader model, serial number, date installed, and distributor from whom purchased.

Buyers Products Company shall not be liable for damage arising out of failure of any unit to operate properly, or failure, or delay in work, or for any consequential damages. No charges for transportation or labor performed on any part will be allowed under this warranty.

The gasoline engine is solely warranted through engine's manufacturer. All engine related warranty claims are to be processed through the engine's manufacturer. This information is explained in the engine owner's manual.

### General Information

#### 1. Recommended Vehicle Requirements:

- SCH072 & SCH096 models: ¾ or 1 ton Pick-up Truck Above 8500# GVWR
- SCH120 models: Flat Bed or Dump Trucks Above 15,000# GVWR

### WARNING

Do not overload vehicle beyond the vehicle's Gross Vehicle Weight Rating (GVWR) or Gross Axle Weight Ratings (GAWR). Check the vehicle's load rating certification sticker for maximum vehicle capacity.

## 2. Average Material Weights:

MATERIAL	WEIGHT (POUNDS PER CUBIC YARD)
#1 Rock Salt	950
#2 Rock Salt	1,215
Coarse Sand - Dry	2,565
Coarse Sand - Wet	3,240

To calculate the total spreader weight (including ice control material); add the empty spreader weight plus the ice control material and spreader accessories.

## 3. Hopper Storage Capacity

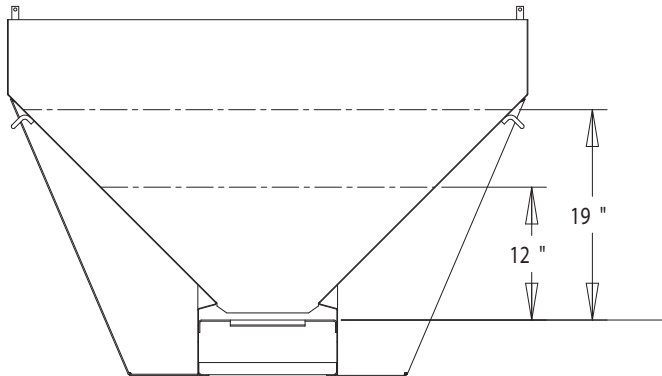

HOPPER CAPACITIES			
	72" HOPPER	96" HOPPER	120" HOPPER
12"	.33 CU-YD	.50 CU-YD	.60 CU-YD
19"	.75 CU-YD	1.0 CU-YD	1.25 CU-YD

## 4. Recommended Fastener Torques:

Maintain all fastener torques as shown in the following table. Failure to do so may cause injury to persons.

	SAE GRADE 2 FT-LBS	SAE GRADE 5 FT-LBS
1/4-20	6	9
5/16-18	11	18
3/8-18	19	31
3/8-24	24	46
7/16-14	30	50
1/2-13	45	75
9/16-12	66	110
5/8-11	93	150

## 5. Engine and Gearbox Oil:

The engine crankcase is filled with 1 quart of SAE 5W-30 motor oil at the factory. The gearbox is filled with SAE 90 gear lubricant at the factory.

### WARNING

Verify that the above oil viscosity meets your operating temperature requirements. If not, empty and refill with the proper viscosity oil. Before starting spreader, check that the engine crankcase and gearbox are filled to the proper level with lubricant.

## Safety Precautions

### WARNING

Observe the following Safety Precautions before, during and after operating this spreader. By following these precautions and common sense, possible injury to persons and potential damage to this machine may be avoided.

1. Read this entire Owner's Manual before operating this spreader. This includes the engine Operator's Manuals.
2. Read all safety decals on the spreader before operating the spreader.
3. Check to make sure all safety guards are securely mounted into place before operating this spreader.
4. Make sure the engine cover is securely fastened to the spreader before operating the spreader.
5. Verify that all personnel are clear of the spreader spray area before starting or operating this spreader.
6. Keep all loose clothing, hair, jewelry and limbs clear of the spreader before starting or operating this spreader.
7. Do not over-load your vehicle beyond payload limits. If there are any questions, contact the vehicle manufacturer.
8. Do not adjust, clean, oil or unclog material jams without first turning off the spreader, removing the engine spark plug connector.
9. Do not climb on or in the spreader during operation. Do not ride on the spreader while the vehicle is in motion.
10. Make sure the spreader is securely fastened to the vehicle in accordance with this manual.
11. Do not operate a spreader that is in need of maintenance or repairs.
12. Never lay tools or equipment on top of the spreader's 12V

DC battery. This could accidentally ground the positive (+) battery terminal, resulting in electrical shock, burns or damage to the vehicle or equipment.

- 13.** Avoid contact with battery acid. Battery acid can seriously burn eyes or skin. Battery acid can also burn holes in clothing.
- 14.** Always disconnect the battery before removing or replacing any electrical components.
- 15.** A charging battery gives off gases that can explode if touched by a spark or flame. Cover the top of the battery with electrically non-conductive material to keep sparks away from battery gases.
- 16.** If the spreader must be operated with the spreader battery disconnected, insulate the positive (red) battery cable and red wire from the engine alternator with electrical tape.

## Installation Instructions

### 1. Mounting the Spreader onto the Vehicle:

- A.** Remove the tailgate from the vehicle.
- B.** Lift the spreader from the lifting loop or square knock-out in hoppers rear cross member (toward rear of the truck). The lifting point is placed at the approximate balance point



**WARNING**

The lifting device must be adequately rated to lift a payload equal to or greater than the spreader weight. See page 1 for spreader weights. Empty spreader before lifting.

of the spreader. Residual material, gasoline, oil, battery, top screen, or inverted vee assembly may affect this balance point.

- C.** Elevate the spreader off the vehicle with lumber. Place lumber under the side gussets of the spreader. This will help with removal of excess material that accumulates under the spreader.
- D.** Center the spreader on the vehicle with the ends of the sill extensions 14" to the rear of the nearest vertical obstruction (bumper, trailer hitch, etc). It is recommended that the Spinner/Chute Assembly be loosely attached to the hopper to avoid any interference between the vehicle and the Spinner/Chute Assembly.
- E.** Bolt the spreader to the vehicle frame through the lengths of lumber using the holes located in each of the four (4) side gussets. Use 1/2" SAE Grade 5 hardware as required by vehicle application.
- F.** In addition secure the spreader to the vehicle by attaching

the four (4) tie-down eyes located at each corner of the spreader to the vehicle's factory installed anchor points using suitable tie-down devices.

- The spreader must be securely fastened to the frame of the vehicle.
- Verify with the vehicle's manufacturer that the factory installed anchor points are designed for tie-down of such load.
- Periodically check that the spreader mounting hardware is securely tightened.

### 2. Mounting the Spinner/Chute Assembly

**A.** Attach the Spinner/Chute Assembly to the spreader using the four (4) 3/8-16 X 3/4" hex head screws, flat washers, lock washers, and nuts. The flat washers are to be placed over the slots in the sill extensions. Push the chute assembly forward towards the cab of the vehicle. Loosely attach the hardware, but do not tighten at this time.

**B.** Install the roller chain between the spinner/chute sprocket and the gearbox sprocket. Make sure both sprockets are in-line with one another. If the sprockets are out of alignment, adjust the height of the gearbox sprocket to correct alignment. Install the roller chain master link.

**C.** To adjust the roller chain tension: First pull the spinner/chute assembly away from the rear of the vehicle to take up slack in chain then tighten chute screws. The correct chain tension should allow a 5/16" deflection midway between both chain sprockets. If additional adjustment is needed, loosen the spinner shaft bearing bolts and slide the shaft away from the gearbox sprocket. Be sure to maintain the vertical alignment of the spinner shaft and bearings before tightening the hardware.



**CAUTION**

Do not over-tension the roller chain. This can cause damage to the chain, bearings, and gearbox.

- D.** Install the chain guard using the three (3) 1/4-20 X 3/4" hex head bolts, lock washers, and nuts.
- E.** Tighten all hardware to the recommended torque specifications as shown in this manual.

### 3. Control Box and Vehicle Wiring Harness Installation.

*The following instructions show how to install the spreader so that the engine will draw power, to start the engine, from a dedicated battery located on the spreader.*

### Cab Control Box

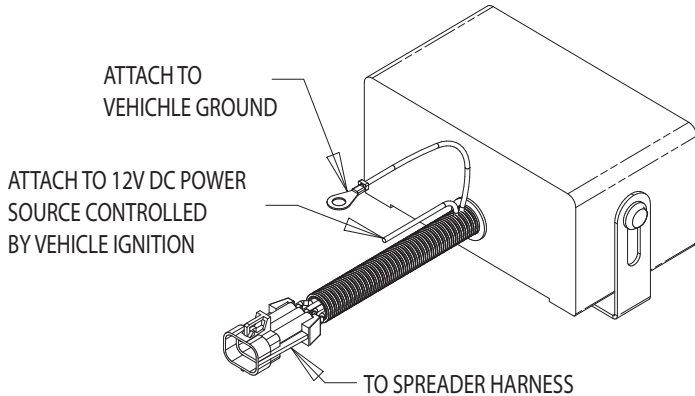

**A.** Layout a wiring path for the vehicle wiring harness.

**WARNING**

Do not drill holes into fuel tanks, fuel lines, through electrical wiring, etc that may be damaged by drilling.

**B.** Mount the control box in a convenient location in the truck cab.

**WARNING**

Do not install control box in the vehicle's airbag deployment area. Refer to the vehicle's manual for airbag deployment area.

**C.** Connect the green wire from the vehicle wiring harness to a known good vehicle ground.

**D.** Connect the stripped end of the red wire to an accessory wire/terminal that is controlled by the vehicle's ignition switch.

### 4. Spreader Wiring Installation

**A.** Attach the terminal end of the black (negative) battery cable to the negative terminal (marked "-") on the battery.

**B.** Then connect the terminal end of the red (positive) battery cable to the positive terminal (marked "+") on the battery.

**C.** Using cable straps and 1/4" x 3/4" sheet metal screws, secure the spreader wiring harness to the spreader. Pre-drilled holes are provided for securing the sheet metal screws.

**D.** Verify that the Ignition Switch in Control Box is in the "OFF" position prior to completing step E.

**E.** Connect the spreader and vehicle wiring harnesses.

### 5. Installing the Inverted Vee Assembly (Optional Equipment)

The front and rear hopper cross members have two (2) holes in each to support the inverted vee deflector weldment. Secure the deflector with four (4) 3/8-16 X 1" hex head cap screws, lock washers, and nuts.

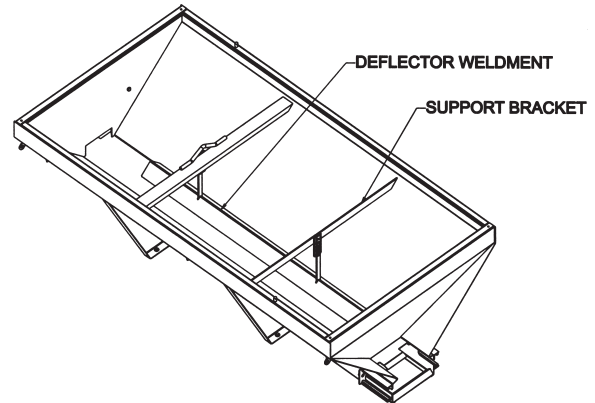

**A.** Adjust the height of the inverted vee for the material being spread:

- For salt and dry sand, adjust the Deflector Weldment as close to the bottom of the hopper as possible.
- For salt/sand mix, adjust the Deflector Weldment to the middle of the mounting holes.
- For wet sand, adjust the Deflector Weldment to the highest position.
- Tighten all hardware according to the recommended torque chart.

### Spreader Operation

Before starting the engine, follow all safety precautions on pages 2 and 3.

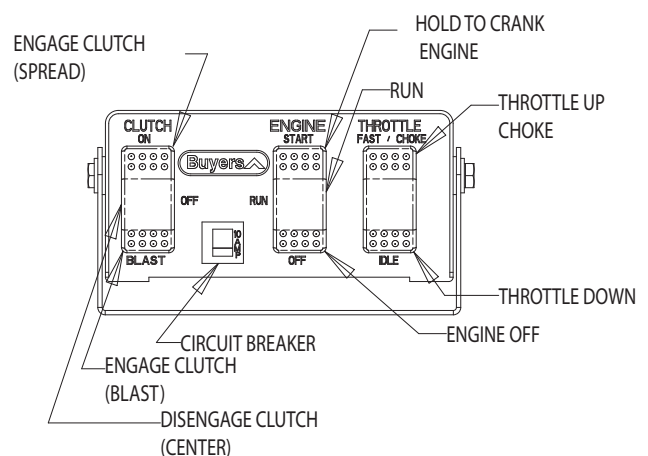

## 1. Cab Control Box Functions:

**A.** The clutch switch is a three position switch with the following functions:

“OFF” position: While in this position, with the engine running, the spreader feed chain and the spinner disk will not spin. Therefore, the spreader will not spread ice control material.

“ON” position: While in this position, the spreader feed chain and the spinner disk will spin with the engine running.

“BLAST” position: While in this position, with the engine running, the spreader feed chain and the spinner disk will spin. In this position switch can only be activated when held into the “BLAST” position.

**B.** The ignition switch is a three position switch with the following functions:

“OFF” position: While in this position, 12V DC power is shut off to the spreader. To turn off the spreader, flip the switch to this position.

“ON” position: While in this position, 12V DC power is turned on to the spreader.

“START” position: While holding in this position, the spreader’s engine starter is activated.

**C.** The throttle switch is a two position switch with the following functions:

“CHOKE/FAST” position: While in this position, the engine speed will increase until the engine linkage reaches its choke position.

“IDLE” position: While in this position, the engine speed will decrease.

## 2. Starting the Engine

**A.** Verify that the clutch switch and ignition switch on the cab control box are in the “OFF” position.

**B.** Turn the vehicle’s ignition to the “ON” position.

**C.** Press the spreader’s ignition switch to the “ON” position.

**D.** Press the throttle switch on the cab control box to the “Idle” position and hold for approximately two seconds.

**E.** Hold the ignition switch in the “START” position.

**F.** While the engine is cranking, press and hold the throttle switch to the “CHOKE/FAST” position.

**G.** Release the ignition and throttle switches when the engine

starts.

**H.** After the engine starts, hold the throttle switch to the “IDLE” position to release the choke (hold switch for 1/2-1 seconds).

## 3. Stopping the Engine

**A.** Reduce engine RPM by holding throttle switch to the “IDLE” position for 2-3 sec. To stop the engine, press the ignition switch to the “OFF” position.

## 4. Clutch Operation

**A.** Start the engine and adjust the speed to slightly above idle.

**B.** Push the clutch switch into the “ON” position.

**C.** Increase the engine RPM by pressing the throttle switch to the “CHOKE/FAST” position.

**D.** It is recommended that the clutch only be engaged at the lowest possible speed without stopping the engine. This practice will prevent premature spinner chain failure and chain tension loss.

**E.** Do not repeatedly use the “Blast” function for the clutch. This practice will prevent premature clutch and flex coupler failure and breakage.

## 5. Spinner/Chute Assembly Operation

**A.** The spread pattern and the amount of material dispensed is dependant on the following factors:

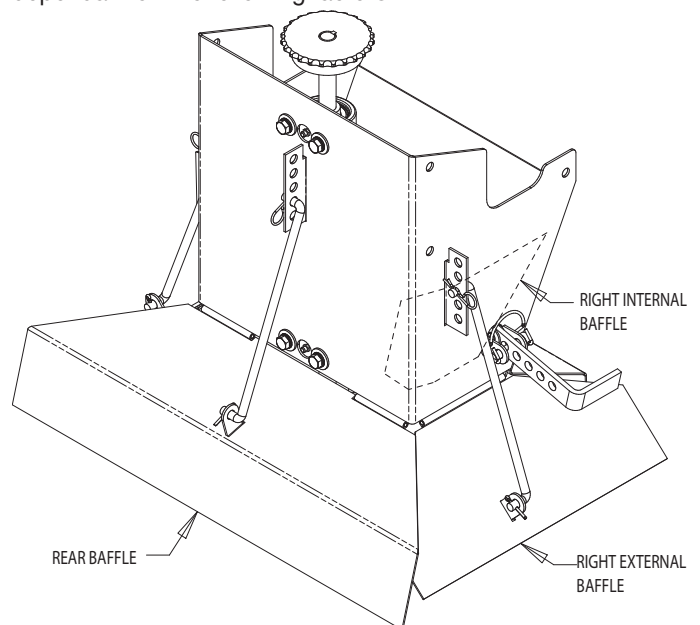

1. Engine RPM.
2. Feed gate position.
3. Baffle settings.

**B.** Keep the following rules in mind:

- Decreasing engine RPM will decrease the

amount of material coming to the spinner.

- Increasing engine RPM will increase the amount of material coming to the spinner.
- Size of the feed gate opening will increase or decrease the amount of material coming to the spinner.

Below are illustrations that show the baffles effect on the spread pattern as viewed from the top of the spinner disk.

## 6. Precautions

### Internal Baffle Adjustment

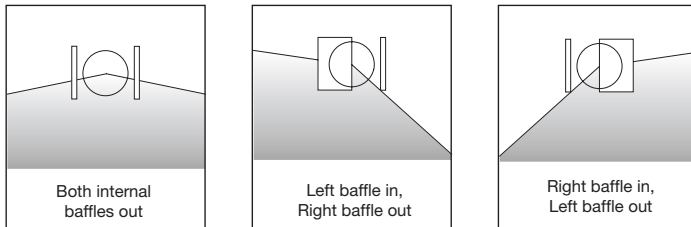

### External Baffle Adjustment

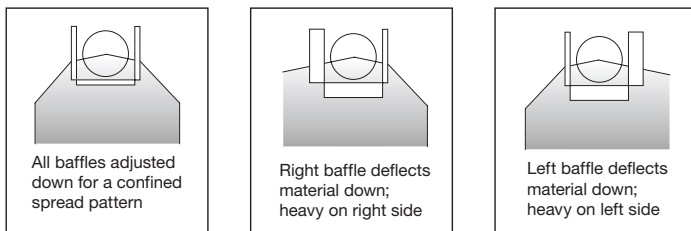

**A.** If the feed chain does not move because of dense material or a material jam, remove all material from the hopper and free the chain.

### WARNING

Always follow the following precautions so as not to cause damage to the spreader.

**B.** If the material in the hopper freezes, move the spreader into a warm area to thaw.

**C.** To prevent the feed chain from freezing, do not store material in the spreader.

**D.** The gearbox is designed to only accept torque from the input shaft. Therefore, **DO NOT ATTEMPT TO FREE THE FEED CHAIN BY USING A PIPE OR SIMILAR TOOL TO MOVE OR DISLODGE THE CHAIN.** If the feed chain is moved, the gears within the gearbox will strip. This action will void all warranties.

**E.** Check and maintain the correct oil level for both the engine crankcase and the gearbox. The engine crankcase is filled with 1 quart of SAE 5W-30 motor oil at the factory. The gearbox is

filled with SAE 90 gear lubricant at the factory.

## Spreader Maintenance

1. Use dielectric grease on all electrical connections before an

### CAUTION

The engine crankcase and gearbox must be filled and maintained with oil. The engine crankcase oil must be of the correct viscosity for the intended spreader operating conditions. Refer to the engine's owner manual to determine the correct viscosity. Operating the engine or gearbox without oil (or without a sufficient amount of oil) can cause permanent damage to the engine or crankcase.

electrical connection is made or after a connector is disconnected.

2. Grease the following:

- Idler shaft bearings (2)
- Drive shaft bearings (2)
- Spinner shaft bearings (2)
- Flanged bearing located between gearbox and clutch.
- Gearbox input shaft (if equipped with fitting)

3. Check gearbox oil level periodically and maintain the oil level by adding appropriate lubricant.

4. Fill the engine crankcase with recommended oil to the full line. Read the engine owner's manual for the recommended oil viscosity for your operating conditions. Check the oil level periodically and maintain the oil level. Clean and lubricate engine's choke throttle linkage.

5. Check the Feed Chain tension periodically.

**A.** To check the tension, measure in 21"-25" from the rear edge of the sills. Push up on the chain with your hand. The conveyor chain should lift up 2"-3" off the conveyor chain guide or cross angles.

6. Maintain the correct tension on the following roller chains:

- A.** Engine to Gearbox Input Sprocket.

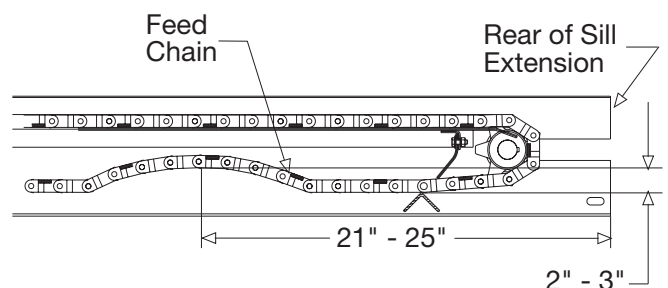

## B. Spinner Shaft to Gearbox Input Sprocket.

The correct chain tension allows 5/16" deflection midway between respective sprockets. Oil both roller chains often, and at the end of each season.

To loosen or tighten Chain A: loosen the four (4) 3/8-16 X 1 carriage bolts that fasten the engine mount stand to the engine deck and slide the engine mount stand.

To loosen or tighten Chain B: First, loosen the spinner chute fasteners and slide the spinner/chute assembly. If additional adjustment is needed, loosen the spinner shaft bearing bolts and slide the spinner shaft. Be sure to maintain the vertical alignment of the spinner shaft and bearings before tightening the hardware.

7. Empty the spreader of all ice control material when not in use to prevent a frozen feed chain.

### CAUTION

Do not over-tension either roller chain. Over-tensioning can cause damage to bearings, roller chain, sprockets, or the engine.

8. Wash out the spreader when it is not in use. At the end of the season wash out the spreader to remove all ice control materials. Thoroughly dry all metal surfaces. Paint and oil all bare metal surfaces and chains to protect from rust. Properly store the spreader for the next season.

9. To minimize problems and extend the life of the electric clutch, the following procedures are recommended:

A. At the end of the season, remove and clean the clutch.

B. After cleaning, coat both mating surfaces of the clutch with oil or light grease.

C. Remove oil and grease prior to using the clutch again.

## 10. Engine Repair

A. Maintain the spreader engine according to the engine owner's manual. This manual is shipped with the spreader. The engine warranty is covered by the engine's manufacturer. If engine service is required, contact an authorized service center for the engine's manufacturer.

## Throttle Motor Assembly Instructions

(diagram on pg. 8)

### Removal Instructions:

1. Carefully observe the existing installation and mark the position of the throttle control bracket on the engine mount stand.

2. Disconnect the wire connections.

### CAUTION

Improper installation of the throttle motor assembly can result in damage to the engine choke/throttle linkage.

3. Remove the 1/4-20 fasteners that hold the throttle control bracket to the engine mount stand. Remove the throttle motor assembly.

### Installation Instructions:

1. Connect the electrical wiring. Only connect the brown wire to brown wire and red wire to red wire.

2. Run the new throttle motor until the crank is within opening of the throttle control bracket.

3. Fasten the new throttle motor to the throttle control bracket using the existing hardware.

4. Place the throttle pin assembly on the crank of the throttle motor using hole in the middle of plastic block.

5. Place the assembly onto the engine mount stand by inserting the throttle pin into the engine choke/throttle linkage slider.

6. Keeping the throttle pin assembly parallel to the engine choke/throttle linkage bolt the assembly to the engine mount stand with the existing hardware.

7. Run throttle motor in both directions until the slider in choke/throttle linkage stops against choke/throttle linkage bracket. Adjust position of throttle bracket if necessary.

## Repair Parts - Engine Subassembly

ITEM	PART NO.	QTY.	DESCRIPTION
1	3006853	1	Stand, Engine Mount
2	-	4	Washer, Lock 5/16"
3	-	4	Nut, Hex 5/16"
4	-	4	Washer, Flat 5/16"
5	-	4	Screw, 5/16-18 x 1.5 Gr 5
6	1410709	1	Throttle Motor Assembly
7	1411911	1	Retainer, Throttle Motor Bracket
8	-	4	Washer, Flat 1/4 SAE
9	1411915	1	Sprocket, Engine Drive
10	KS402	1	Key, 1/4" x 2"
11	1306070	1	Solenoid
12	-	3	Nut, Hex 1/4-20
13	-	3	Washer, Lock 1/4"

ITEM	PART NO.	QTY.	DESCRIPTION
14	-	5	Screw, 1/4-20 x 3/4" Gr 5
15	3006887	1	Engine, Gas, 10½ HP Briggs & Stratton
15	3005709	1	Engine, Gas, 10 HP Tecumseh
16	1411910	1	Throttle Pin Assembly
17	3001378	1	Cable, Battery 14" (Black)
18	3001379	2	Cable, Battery 14" (Red)
19	-	1	Terminal, 1/4" Ring
20	-	1	Terminal, 5/16" Ring
21	-	-	Red Wire, 16 GA
22	-	3	Screw, #8-32 x 5/8" Machine. Pan HD
23	-	3	Nut, #8-32 Nylock
24	3003228	1	Bracket, Throttle Control, Briggs & Stratton
24	1410714	1	Bracket, Throttle Control, Tecumseh

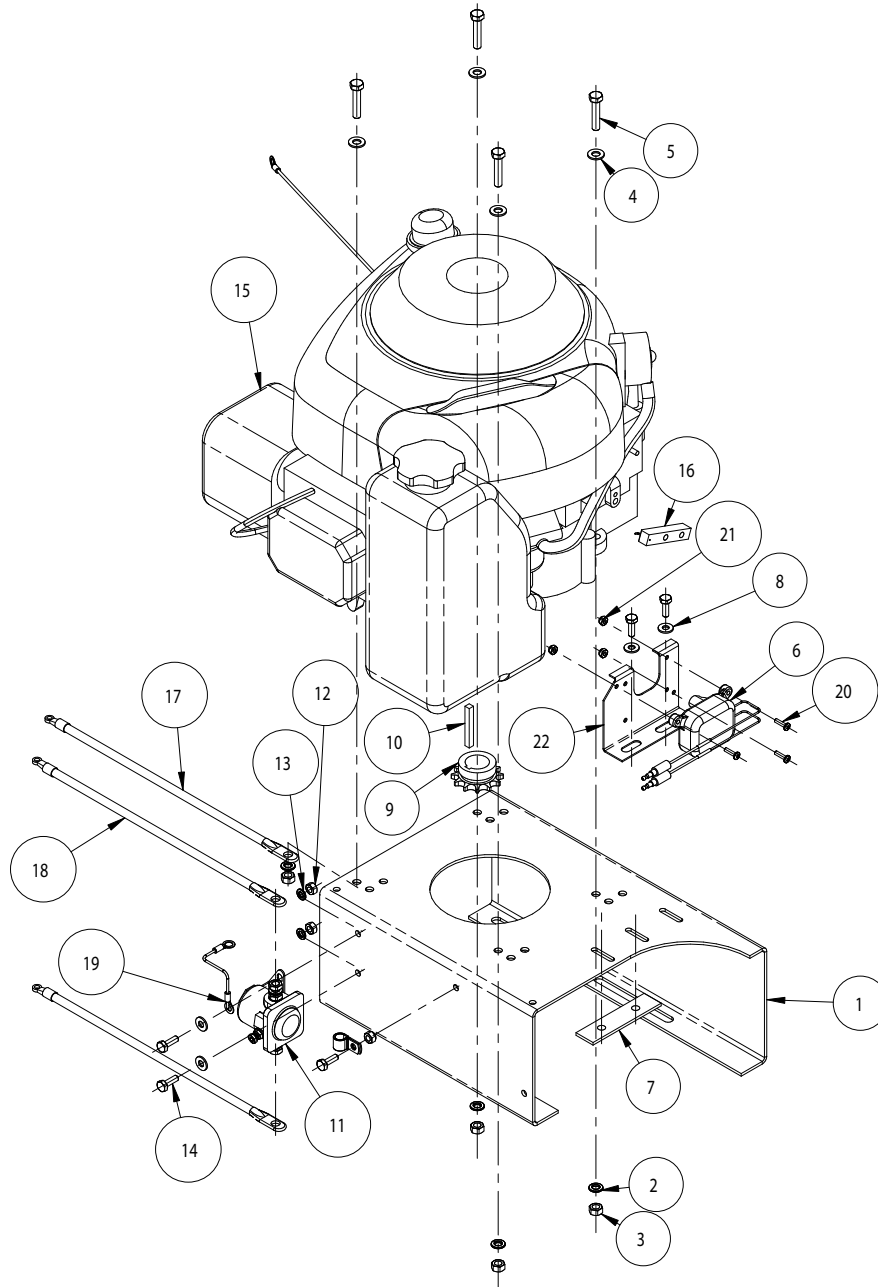

## Repair Parts - Spinner/Chute Assembly

ITEM	PART NO.	QTY.	DESCRIPTION
1	3001306	1	Chute Housing Subassembly-STD CS
1	3001405	1	Chute Housing Subassembly-EXT CS
1	3002114	1	Chute Housing Subassembly STD SST
1	3002120	1	Chute Housing Subassembly EXT SST
2	FPC007800075	1	Cotter Pin, 5/64 X 3/4
3	1420014	1	Clevis Shear Pin, 1/4 X 2-1/2
4	3004611	1	Spinner Disc 11.5 Dia. Poly
5	1420015	3	Control Rod
6	FPC013000100	1	Cotter Pin, 1/8 X 1
7		4	H. Head Cap Screw 3/8-16 X 3/4 GR5
8		4	Hex Nut 3/8-16
9		4	3/8 Flat Washer
10		4	3/8 Lock Washer
11	1420016	3	Hairpin Cotter, 3/32 X 2
12	1420018	2	Lynch Pin, 3/8 X 1-3/4

ITEM	PART NO.	QTY.	DESCRIPTION
13		4	H. Head Cap Screw, 3/8-16 X 3/4, GR5
14		4	3/8 Flat Washer
15		4	3/8 Lock Washer
16	1420101	2	Pillow Block Bearing, 3/4"
17	1420150	1	Spinner Shaft-STD
17	142X150	1	Spinner Shaft-EXT
18	KS301	1	Key, 3/16" Square X 1"
19	1420004	1	Sprocket, 24 Tooth w/ Set Screw
20	1410711	1	Roller Chain, #40, w/ 80 Links
21	3002225	1	Collar, .75 dia. Lock w/Two Set Screws,3/16 Keyway
22	141055K	1	Kit,STD LG , Shaft, Bearing, Sprocket, Spinner Disk, & HDW
22	141065K	1	Kit EXT LG,Shaft, Bearing, Sprocket, Spinner Disk, & HDW

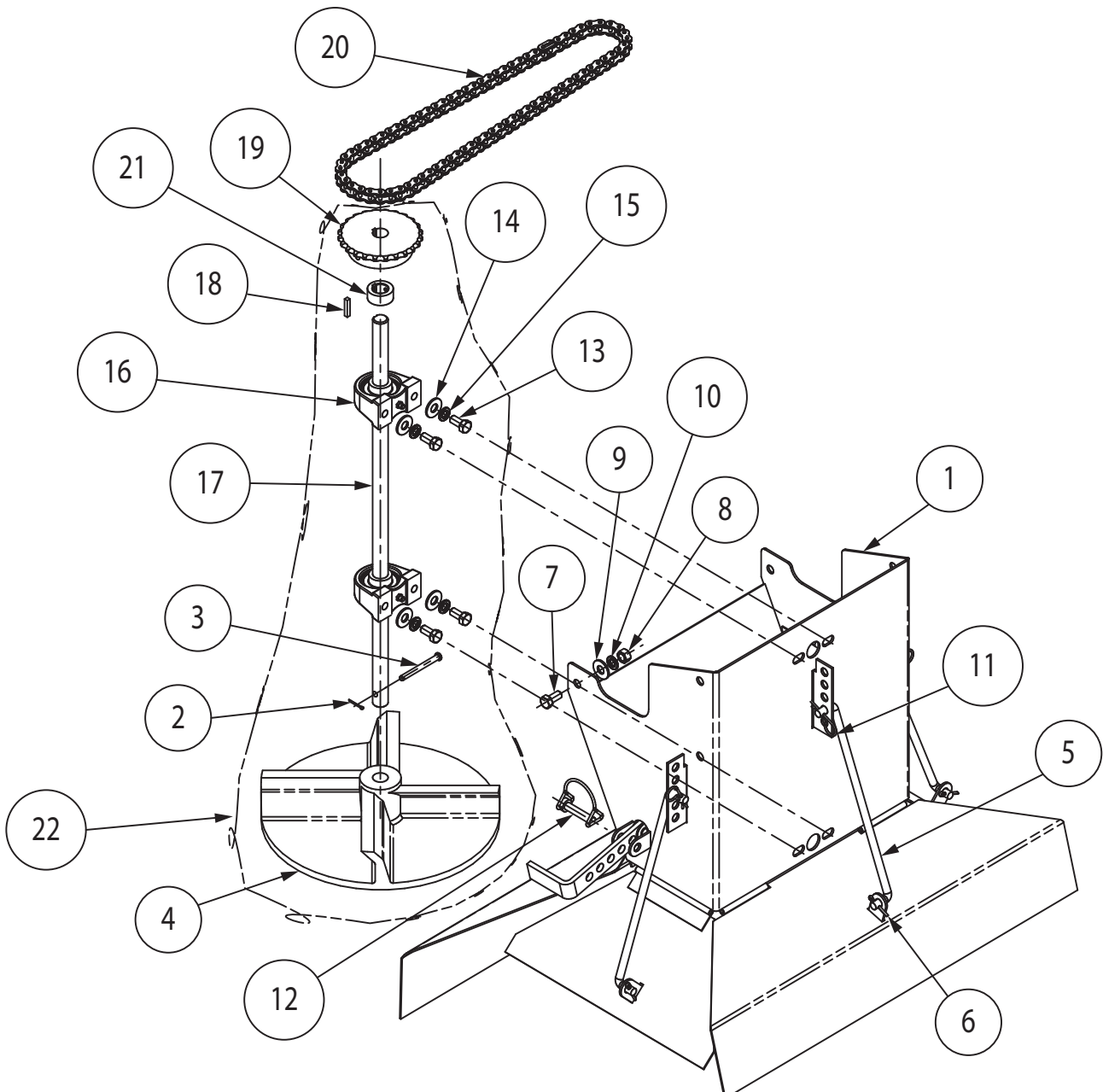

## Repair Parts - Drive Subassembly

ITEM	PART NO.	QTY.	DESCRIPTION
1	3006861	1	Engine Deck Weldment SST
1	3007189	1	Engine Deck Weldment Carbon Steel
2	1410720	1	Gearbox Assembly
-	1410702	1	Sprocket, 16 Tooth
3	1401150	1	Clutch Assembly
4	1411000	1	Bearing, 2-Hole Flanged, 1" ID
5	1411800	1	Sprocket, Clutch 52 Tooth
6	3006856	1	Engine Shroud Weldment SST
6	3007184	1	Engine Shroud Weldment Carbon Steel
7	1410717	1	Battery, 12 VDC
8	3001363	2	Bracket, Battery Mount
9	1410216	-	Sponge, Rubber
10	-	4	Screw, 1/2-13 x 1 Gr 5
11	-	4	Washer, Lock 1/2"
12	1411500	2	Collar, 1" ID
13	-	2	Screw, 5/16-18 x 1-1/2 Gr 5
14	-	2	Washer, Flat 5/16 SAE
15	3006917	1	Engine, Assembly 10½ HP Briggs & Stratton
15	3005735	1	Engine, Assembly 10 HP Tecumseh
16	3002390	2	Pin, Pivot 3/16 x 1-5/8"
17	-	3	Screw, 5/16 - 18 x 5/8"

ITEM	PART NO.	QTY.	DESCRIPTION
18	-	4	Bolt, Carriage 3/8-16 x 1"
19	-	6	Washer, Flat 3/8 USS
20	-	4	Washer, Lock 3/8"
21	-	4	Nut, Hex 3/8-16
22	-	5	Washer, Lock 5/16"
23	-	3	Nut, Hex 5/16-18
24	3002113	1	Guard, Engine Base SST
24	3001381	1	Guard, Engine Base Carbon Steel
25	3002398	2	Strap, Rubber Latch Steel Spreaders
25	3000281	2	Strap, Rubber Latch SST Spreaders
26	3002392	2	Cotter Pin 1/16 dia. x 1/2" SST
27	-	7	Screw, 1/4-20 x 3/4 Gr 5
28	-	7	Nut, Hex 1/4-20
29	-	7	Washer, Flat 1/4" SAE
30	-	7	Washer, Lock 1/4"
31	1412300	1	Chain, #40 Roller, 78 Pitches
32	1413200	1	Grommet, 1-1/2" Rubber
33	-	2	Pin. Hair Cotter 3/32 x 2 SST

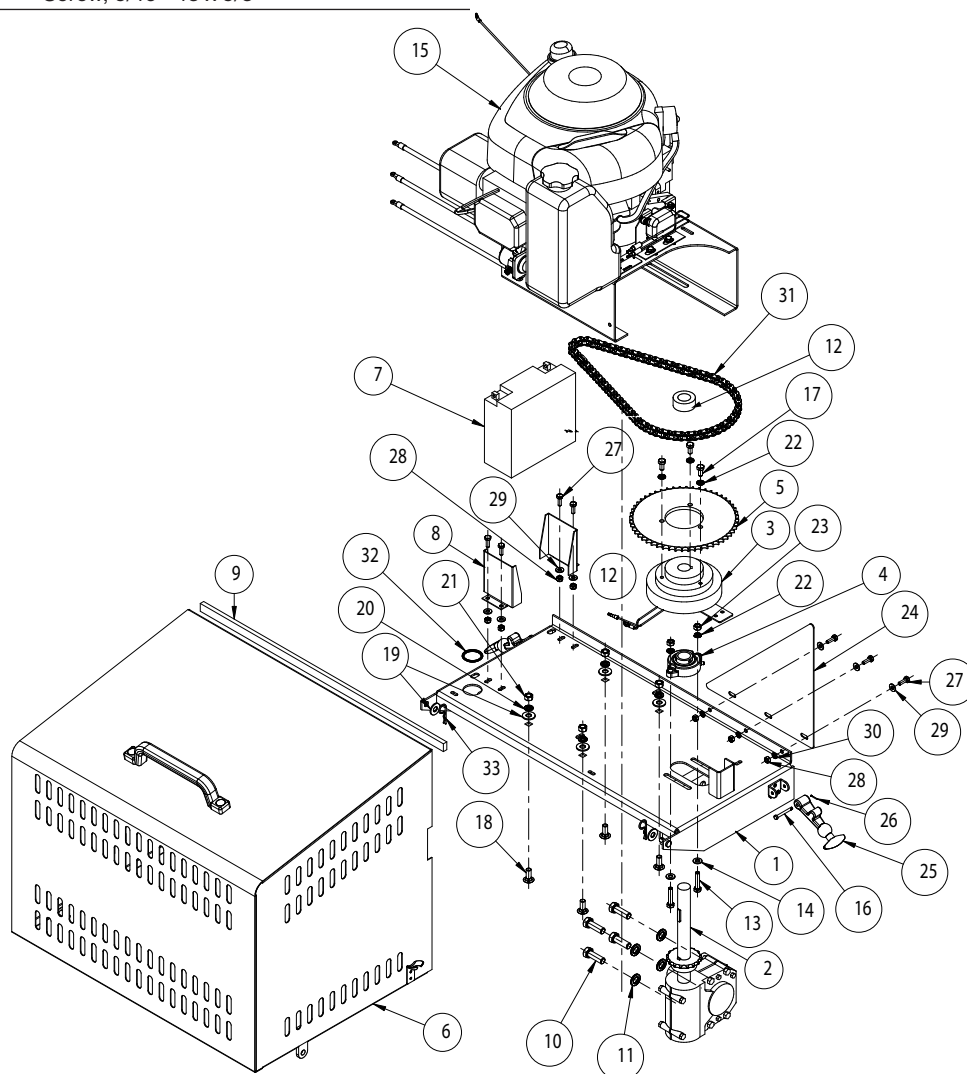

### Repair Parts - Drive Subassembly

ITEM	PART NO.	QTY.	DESCRIPTION
1	1410200	2	Bearing, 2 Hole Flanged, 1-1/8" ID
2	1410250	2	Drive Sprocket, Cast
3	1401100p	1	Pintle Chain Assembly 96" Spreader
3	1401300	1	Pintle Chain Assembly 72" Spreader
3	1401500	1	Pintle Chain Assembly 120" Spreader
4	KS402	2	Key, 1/4" X 1/4" X 1-1/2"
5	1410712	1	Drive Shaft
6	3007461	1	Weldment, Idler Take-up
7	1411001	2	Bearing, Idler Take-up
8	1410706	1	Coupling
9	3007952	1	Chain Guard CS
9	3007950	1	Chain Guard SST
10		2	Set Screw, 1/4-20 X 1/4"
11		4	Washer, Split Lock, 3/8-16
12		4	Nut, 3/8-16 GR 5
13	1410305	4	Screw- Leveler, 3/8-16 X 1-1/4"

ITEM	PART NO.	QTY.	DESCRIPTION
14	1410803	2	Clevis Pin, 3/8" X 2"
15	FPC013000100	2	Cotter Pin, 1/8" X 1"
16	141050W	2	Weldment, Take-up Bolt
17		5	Screw, Hhc, 1/4-20 X 1" GR 5
18		5	Nut, Hex 1/4-20 GR 5
19		5	Washer, Lock, 1/4"
20		2	Nut, Hex, 5/8-11 GR 5
21	1410241	1	Wiper Belt, Hopper
22		5	Washer, Flat, 1/4"
23	1410708	1	Wire Harness For Hopper Spreader
24	3002270B	1	Sill Extention R.H. 96" Hopper
24	3002270SS	1	Sill Extention R.H. SST
25	3002269B	1	Sill Extention L.H. 96" Hopper
25	3002269SS	1	Sill Extention L.H. SST
26		8	Screw, Btn HD Soc Cap 1/2-13 X 1" SST
27		8	Nut, Hx Flng 1/2-13 SST

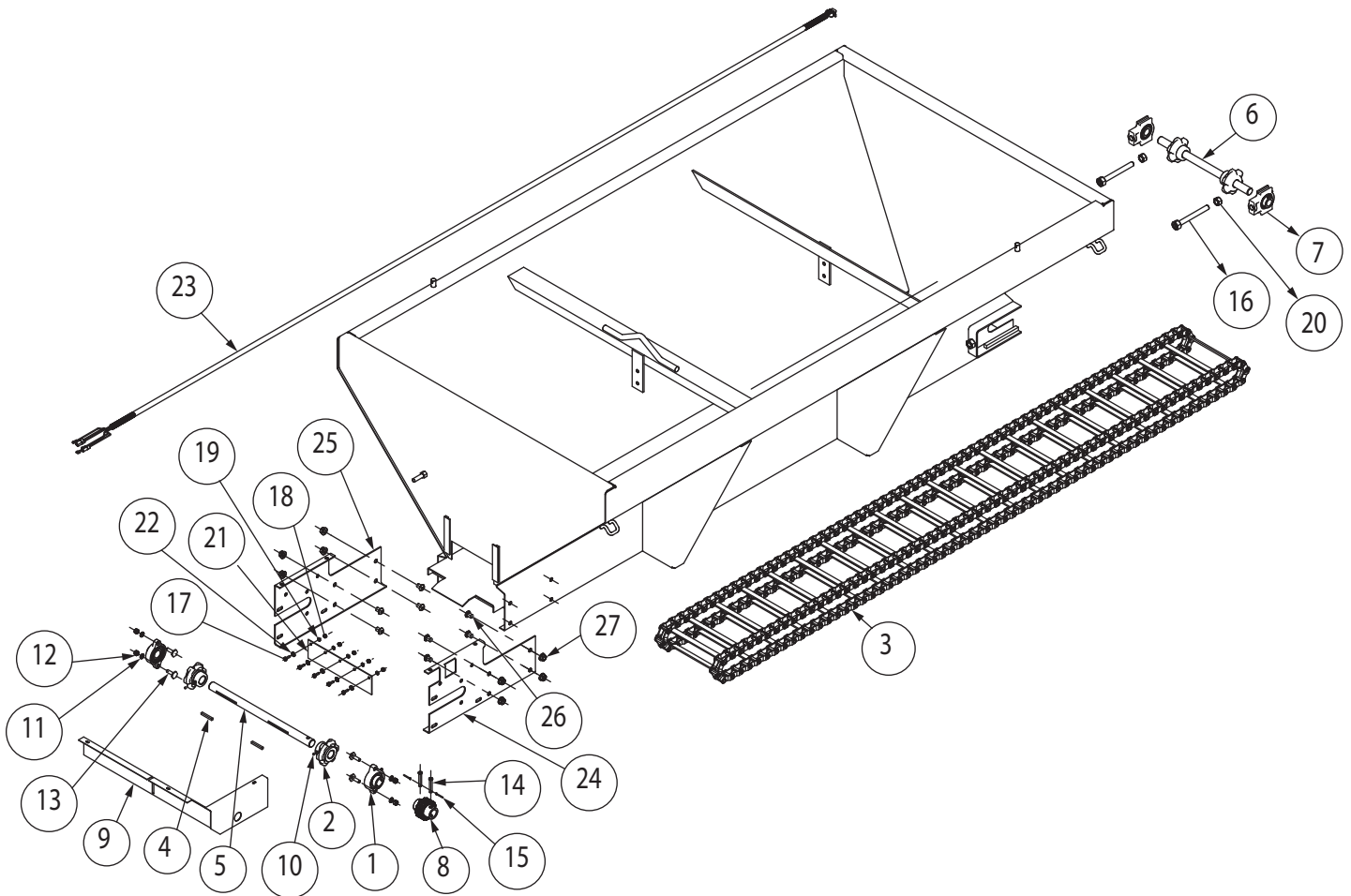

## Repair Parts - Feed Gate Assembly

ITEM	PART NO.	QTY.	DESCRIPTION
1	1410108	1	Feed Gate Lever, CS
1	1410108SS	1	Feed Gate Lever, SST
2	1410109	1	Lever Nut, CS
2	1410109SS	1	Lever Nut, SST
3		1	Bolt Carriage 3/8-16 X 1-1/4" ZN
3		1	Bolt Carriage 3/8-16 X 1-1/4" SST
4		2	3/8 Flat Washer ZN
4		2	3/8 Flat Washer SST
5		1	3/8-16 Hex Locknut ZN
5		1	3/8-16 Hex Locknut SST
6	141010W	1	Feed Gate Panel Weldment, CS
6	141010WSS	1	Feed Gate Panel Weldment, SST

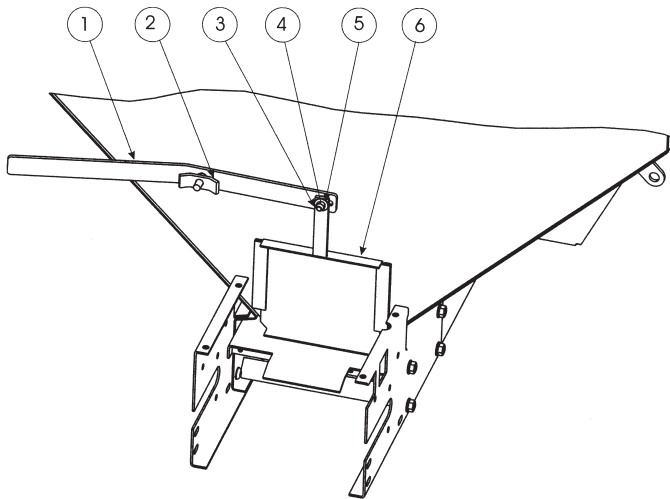

## Hopper Spreader Accessories

ITEM	PART NO.	DESCRIPTION	WEIGHT
1	1496505	Spreader Hold Down Kit, 1-3/4" x 5' Straps (4)	9 lbs.
2	1499700SS	Inverted Vee, Stainless Steel, fits SCH072SS-series	12 lbs.
2	1499500SS	Inverted Vee, Stainless Steel, fits SCH096SS-series	15 lbs.
2	1499500	Inverted Vee, Carbon Steel, fits SCH096C-series	20 lbs.
2	1499300SS	Inverted Vee, Stainless Steel, fits SCH120SS-series	18 lbs.
3	1493500	Hopper Side Extensions, 12" CS, fits 50" Wide SCH096C-series	160 lbs.
3	1493505	Hopper Side Extensions, 12" CS, fits 47" Wide SCH096C-series	153 lbs.
3	1493500SS	Hopper Side Extensions, 12" SST, fits 50" Wide SCH096SS-series	99 lbs.
3	1493501SS	Hopper Side Extensions, 12" SST, fits 47" Wide SCH096S series	92 lbs.
3	1493505SS	Hopper Side Extensions, 12" SST, fits SCH120SS-series	106 lbs.
4	1498550	Heavy-Duty Top Screen, 50" wide, fits SCH096-series	105 lbs.
4	1498551	Heavy-Duty Top Screen, 47" wide, fits SCH096-series	79 lbs.
4	1498560	Heavy-Duty Top Screen, 50" wide, fits sSCH072-series	87 lbs.
4	1498561	Heavy-Duty Top Screen, 47" wide, fits SCH072-series	63 lbs.
4	1498571	Heavy-Duty Top Screen, fits SCH120-series	103 lbs.
5	1491301	Tarp Kit for SCH120-series spreaders 120" x 47"	9 lbs.
5	1491500	Tarp Kit for SCH096-series spreaders 96" x 50-1/2"	8 lbs.
5	1491501	Tarp Kit for SCH096-series spreaders 96" x 47"	8 lbs.
5	1491700	Tarp Kit for SCH072-series spreaders 72" x 50-1/2"	7 lbs.
5	1491701	Tarp Kit for SCH072-series spreaders 72" x 47"	7 lbs.

