

# Engineering Specification

Job Name \_\_\_\_\_  
 Job Location \_\_\_\_\_  
 Engineer \_\_\_\_\_  
 Approval \_\_\_\_\_

Contractor \_\_\_\_\_  
 Approval \_\_\_\_\_  
 Contractor's P.O. No. \_\_\_\_\_  
 Representative \_\_\_\_\_

## Series 800M4QT Anti-Siphon Pressure Vacuum Breakers

**Sizes: 1/2" – 2"**

Series 800M4QT is designed to prevent back-siphonage of contaminated water into a potable water supply. The valve is ideally suitable for irrigation systems, industrial process water systems and other continuous pressure piping system applications where the water enters the equipment at or below its flood rim. The disc float and check valve are suitable for temperatures up to 140°F. The resilient sealing float o-ring and seal check disc are silicone rubber which is resistant to heat, shock and chemical attack.

### Features

- Replaceable plastic seat
- Easy maintenance of internal parts
- Acetal bonnet acts as "freeze plug" to prevent body damage
- O-ring bonnet seal for less possibility of fouling
- Silicone seat disc for durability
- Test cocks positioned for easy testing and winterization
- Compact space saving design
- Standardly equipped with tee handle quarter turn ball valve shutoffs 1/2" – 1". The 1 1/4" – 2" feature lever handles
- No special tools required for servicing
- Bronze body for durability

### Specifications

An anti-siphon pressure vacuum breaker shall be installed where indicated on the plans to prevent the back-siphonage of contaminated water. This assembly is not to be used where there is a possibility that a back pressure condition may develop. The assembly will incorporate an acetal bonnet with silicone rubber O-ring seal and silicone rubber seat disc. The valve shall have replaceable seats. Check assembly shall be guided over its full stroke by 'V' notched guides. The assembly shall meet the requirements of ANSI/ASSE Standard 1020. Watts Series 800M4QT.

#### NOTICE

The information contained herein is not intended to replace the full product installation and safety information available or the experience of a trained product installer. You are required to thoroughly read all installation instructions and product safety information before beginning the installation of this product.

#### NOTICE

Inquire with governing authorities for local installation requirements



800M4QT

1/2" - 3/4"

800M4QT

1" - 2"

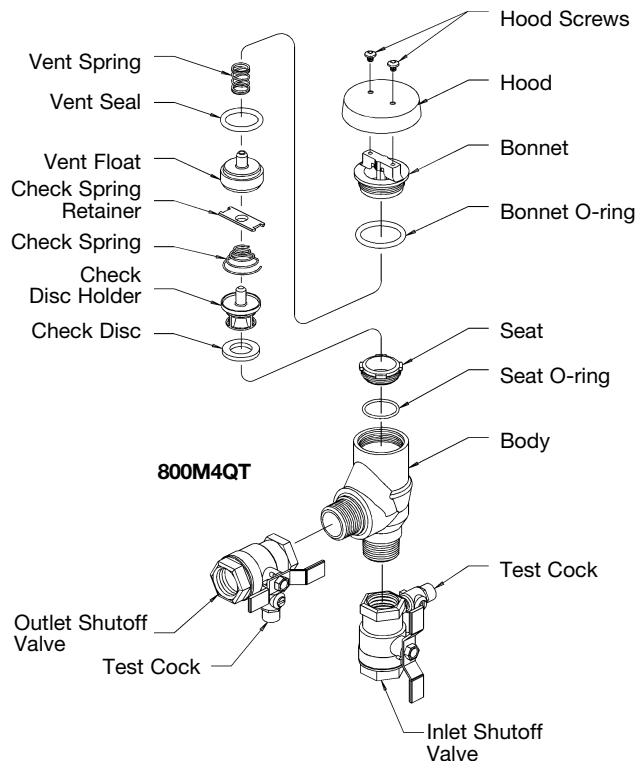

800M4QT

Outlet Shutoff Valve  
 Test Cock

Inlet Shutoff Valve

**Now Available**  
**WattsBox Insulated Enclosures.**  
 For more information, refer to literature ES-WB.

Watts product specifications in U.S. customary units and metric are approximate and are provided for reference only. For precise measurements, please contact Watts Technical Service. Watts reserves the right to change or modify product design, construction, specifications, or materials without prior notice and without incurring any obligation to make such changes and modifications on Watts products previously or subsequently sold.



## Available Models

Prefix  
**U** Union connections (3/4" - 1" only)  
 Suffix:  
**QC** Quick-Connect Adapters  
**SH** Stainless Steel Ball Valve Handles

## Materials

Springs Stainless Steel  
 Bonnet Celcon  
 Vent Disc Silicone Rubber  
 Disc Holder Float Polypropylene  
 Check Valve Disc Silicone Rubber  
 Check Valve Seat Noryl Plastic  
 Body Bronze

## Pressure - Temperature

Temperature Range: 33°F to 140° (0.5°C to 60°C)  
 Maximum Working Pressure: 150psi (10.3 bar)

## Installations

This valve is designed for installation in a continuous pressure potable water supply system 12" above the highest point of the downstream piping. The valve must be installed with the supply connected to the bottom and in a vertical position. Allow adequate space for periodic inspection, servicing or testing. The valve should not be installed in an area where freezing or spillage will cause damage. Adequate drainage/freeze protection must be provided in cold weather applications. 1.5psi (10 kPa) must be exerted against the float spring to seal the float and air inlet. Do not undersize supply and discharge piping.

### NOTICE

Vacuum breakers are not designed, tested or approved to protect against backpressure backflow or water hammer shock. For protection against backpressure backflow, install Watts 909/009 Reduced Pressure Zone Backflow Preventer. For Protection against water hammer shock install a Watts Series 15 Water Hammer Arrestor utilizing good plumbing practice.

## Standards

ANSI, USC

Approvals    USC-FCCCHR

Approved by the foundation for Cross-Connection Control and Hydraulic Research at the University of Southern California. (1/2" - 2" 800M4QT only)  
 CSA (1/2" - 2" 800M4QT only).

\*\*QC models have quick-connect adapters which attach separately to the approved 800M4QT

## Dimensions – Weights

### 800M4QT

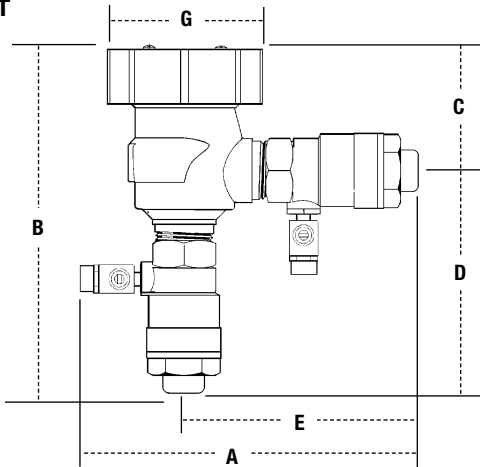

### U800M4QT

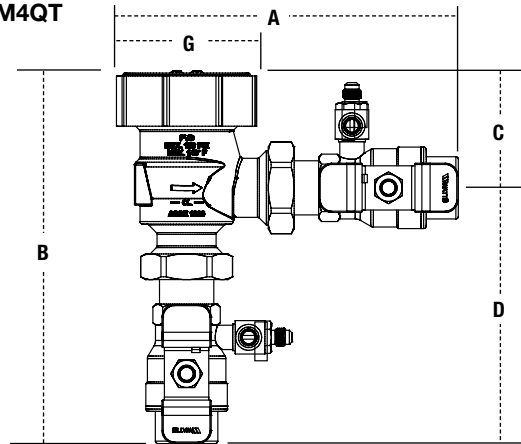

MODEL	SIZE	DIMENSIONS										WEIGHT			
		A		B		C		D		E		G		lbs.	kg.
	in.	in.	mm	in.	mm	in.	mm	in.	mm	in.	mm	in.	mm		
800M4QT	1/2	6 1/8	156	6 1/4	159	2 9/16	65	3 1/16	94	3 7/8	98	2 1/4	57	4	1.8
800M4QT	3/4	6 1/2	165	6 1/2	165	2 9/16	65	3 1/16	100	4 1/8	105	2 1/4	57	4	1.8
800M4QT	1	7 1/2	191	7 1/2	191	2 3/4	70	4 3/4	121	4 7/8	124	3 7/16	87	6	2.7
800M4QT	1 1/4	8 7/8	225	9	229	3 1/4	83	5 3/4	146	6 1/8	156	5	127	11	5.0
800M4QT	1 1/2	9 1/4	235	9 1/2	241	3 1/4	83	6 1/4	159	6 3/8	162	5	127	14	6.3
800M4QT	2	10 5/8	270	9 5/8	245	3 1/4	83	6 3/8	162	7	178	5	127	19	8.6
U800M4QT	3/4	6 3/8	163	7 9/16	192	2 1/8	55	5 7/16	138	-	-	2 1/4	57	4	1.8
U800M4QT	1	8 5/16	211	9	229	2 13/16	71	6 3/16	158	-	-	3 7/16	87	6	2.7
** 800M4QT-QC	1/2	7 7/8	200	8	203	2 13/16	71	5 7/16	138	5 5/8	144	3 7/16	87	4.5	2.0
** 800M4QT-QC	3/4	8 1/2	216	8 1/2	216	2 13/16	71	5 11/16	144	6 1/8	156	3 7/16	87	4.7	2.1
** 800M4QT-QC	1	9 1/2	241	9 1/2	241	2 13/16	71	6 3/4	171	6 7/8	175	3 7/16	87	6.6	3.0