

Class 125 Bronze Gate Valves

Screw-in Bonnet • Non-Rising Stem • Solid Wedge

125 PSI/8.6 Bar Saturated Steam to 353° F/178° C
200 PSI/13.8 Bar Non-Shock Cold Working Pressure

CONFORMS TO MSS SP-80

MATERIAL LIST

PART	SPECIFICATION
1. Handwheel Nut	300 Series Stainless Steel
2. Identification Plate	Aluminum
3. Handwheel	a. Malleable Iron ASTM A 47 (T-113) b. Bronze (T-113-BHW) c. Bronze Cross (T-113-K)
4. Stem	Silicon Bronze ASTM B 371 Alloy C69400/C69430 or ASTM B99 Alloy C65100
5. Packing Nut	Bronze ASTM B 62 or ASTM B 584 Alloy C84400 or Brass ASTM B 16
6. Packing Gland	Bronze ASTM B 62 or ASTM B 584 Alloy C84400 or Brass ASTM B 16
7. Packing	Aramid Fibers with Graphite
8. Stuffing Box	Bronze ASTM B 62
9. Bonnet	Bronze ASTM B 62
10. Body	Bronze ASTM B 62
11. Wedge	Bronze ASTM B 62

DIMENSIONS—WEIGHTS—QUANTITIES

Size	Dimensions						T-113		S-113		Master Ctn. Qty.	
	In.	mm.	In.	mm.	In.	mm.	In.	mm.	Lbs.	Kg.		Lbs.
¼ †	8	1.69	43	3.38	86	x	x	0.74	0.33	x	x	50
⅜ †	10	1.69	43	3.38	86	.69	18	0.71	0.32	0.65	0.29	50
½ †	15	1.94	49	3.63	92	.75	19	0.82	0.37	0.67	0.31	50
¾	20	2.06	54	3.91	99	.88	22	1.10	0.50	0.99	0.45	50
1	25	2.44	62	4.69	119	1.00	25	1.82	0.82	1.60	0.72	30
1¼	32	2.63	67	5.22	133	1.19	32	2.40	1.09	2.25	1.02	20
1½	40	2.88	72	6.25	159	1.25	33	3.51	1.59	3.17	1.44	10
2	50	3.06	78	7.06	179	1.31	34	4.93	2.24	4.60	2.09	10
2½	65	4.13	105	8.41	224	1.81	46	9.96	4.52	8.78	3.98	5
3	80	4.50	114	10	254	1.94	49	14.40	6.53	12.84	5.82	4

† No packing gland, packing only in these sizes.

x Not available this size.

T-113

Threaded

S-113

Solder

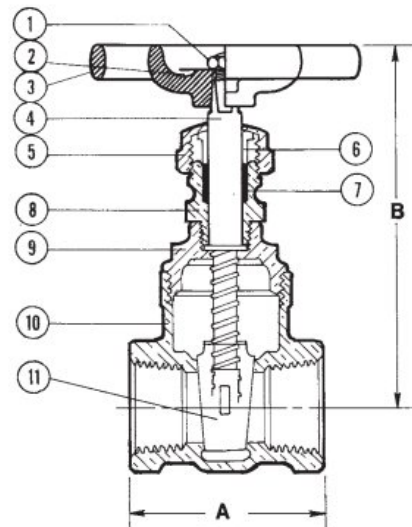
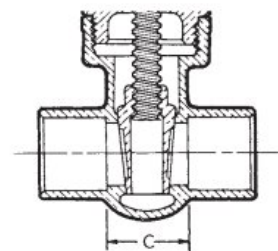
T-113
 NPT x NPT

S-113
 C x C

FREEZING WEATHER PRECAUTION: Subsequent to testing a piping system, valves should be left in an open position to allow complete drainage.

♦ For detailed Operating Pressure, refer to Pressure Temperature Chart on page 113.